

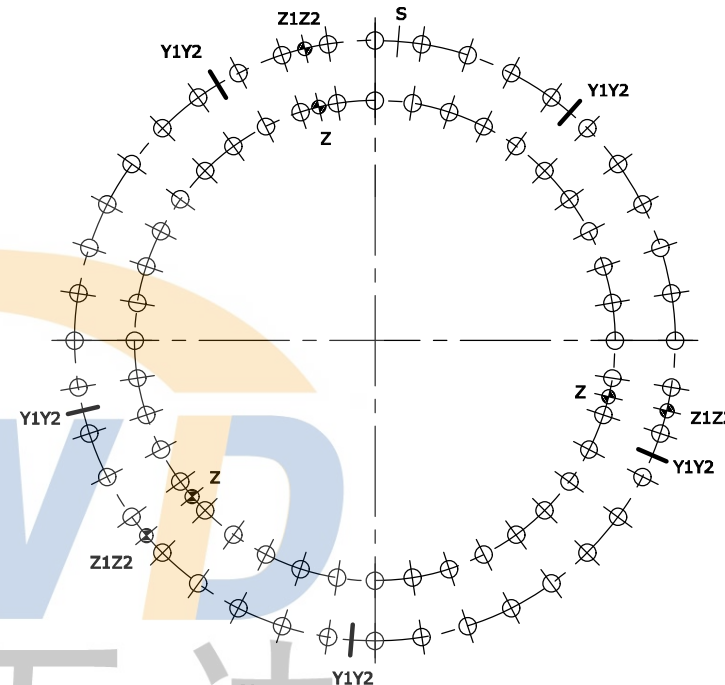

6.3
U.O.N

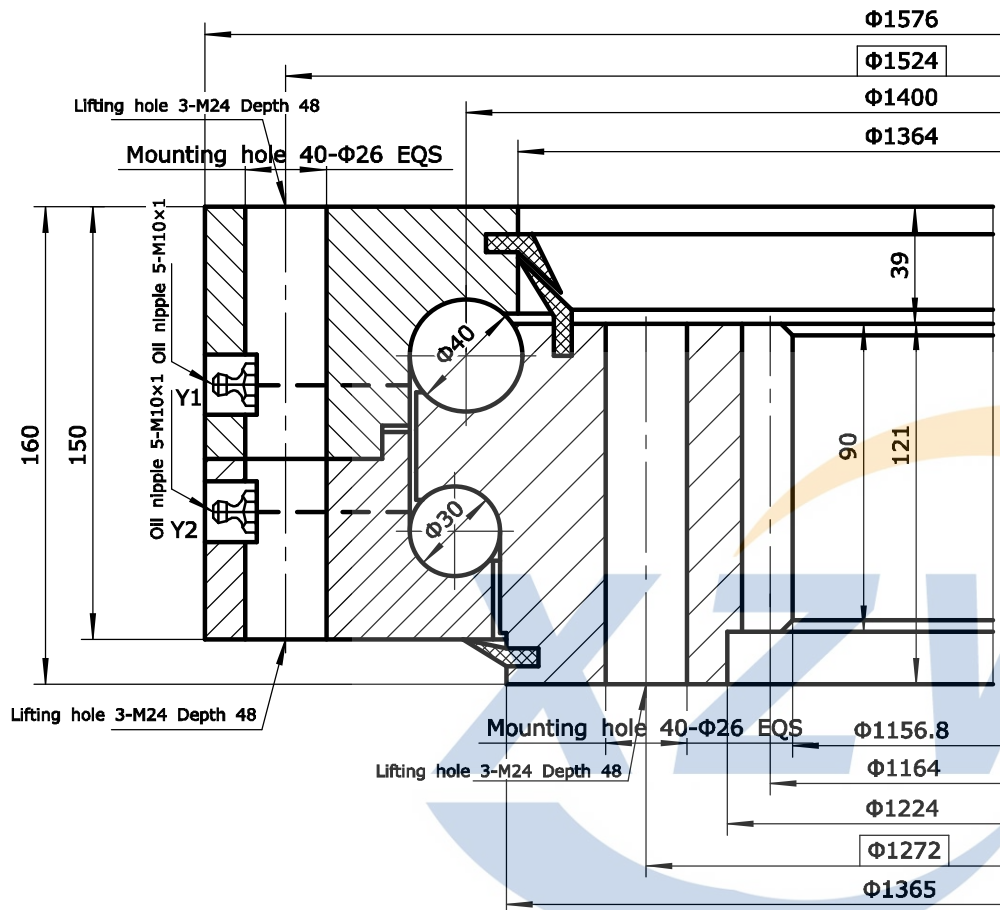

Notes:

1. Raceway of inner & outer ring induction hardened. hardness: 55~62HRC
Depth ≥ 3.5mm
2. Inner & outer ring quenched & tempered, hardness: 207~262HB

Gear Data				Design		Check		Machine tolerances without notes				Model	023.40.1400		Weight	650kg	
Module	m	12	Gear heat treatment requirements		Date	Approve						Name	Slewing Bearing	Qty	Scale		
Teeth no	z	97	HRC		Qty	Size	Axial clearance	0.10~0.40		≤200	≤500	≤710	≤1120	Material	50Mn	Total 1 page	The 1st page
Teeth pressure angle	α	20°	Precision(GB10095-88)	10	Inner ring mounting hole	40	Φ26	Radial clearance	0.20~1.00	±0.30	±0.40	±0.50	±0.65	<p style="text-align: center;">XUZHOU WANDA SLEWING BEARING CO.,LTD</p>  <p>Fax: +86 516 83309366 Fax: +86 516 83915766 http://www.slew-bearing.com</p>			
Modification coefficients	x	+0.5			Outer ring mounting hole	40	Φ26										
Reduction coefficients	km	2.4			Oil hole	2x5	M10x1										
Pitch diameter	d	1164							≤1600	≤2000	≤2500	≤3150					
								±0.80	±0.95	±1.10	±1.35						
								≤4000	≤5000								
								±1.65	±2.0								
								Technical processing standards without notes according to ...JB/T2300-2011									