

Autodesk

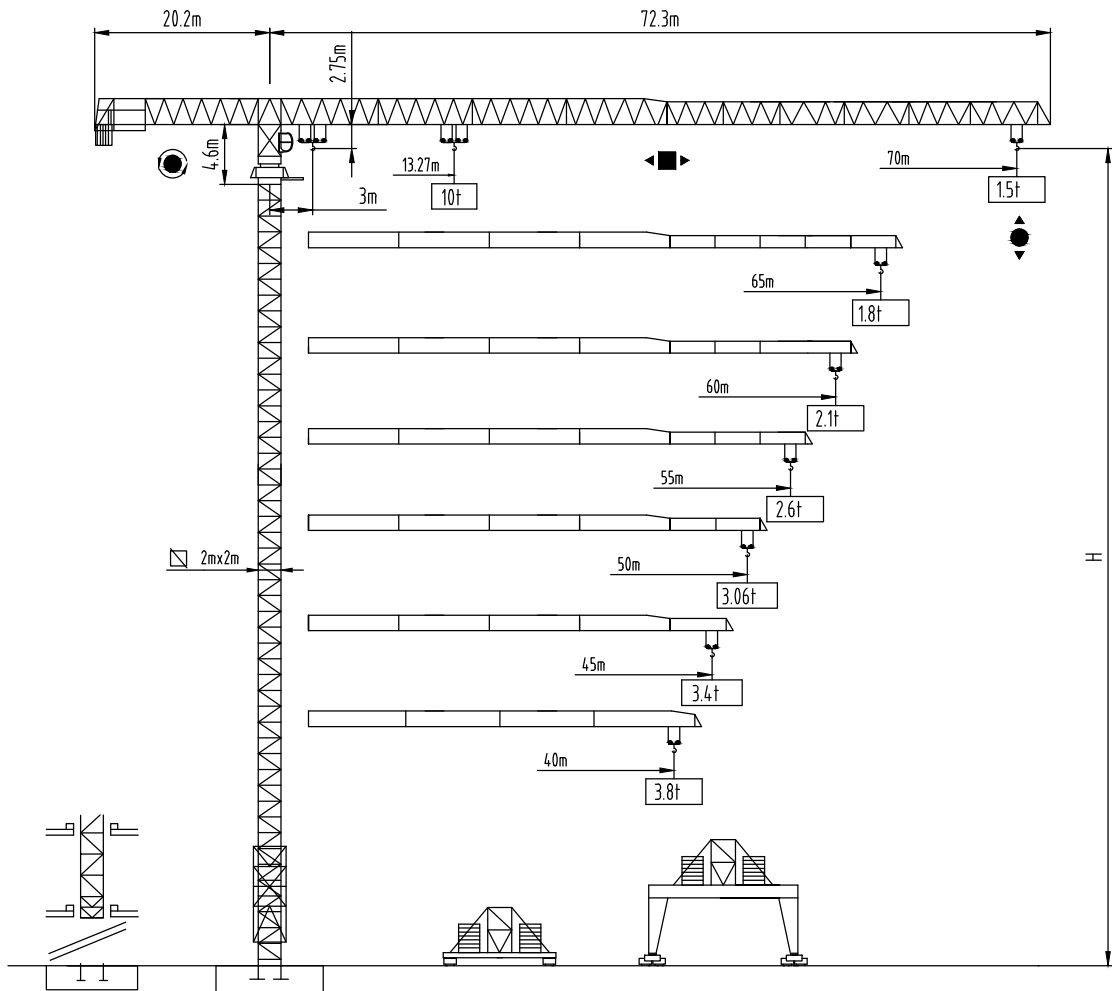

沈阳三洋建筑机械有限公司  
SHENYANG SANYO BUILDING MACHINERY CO., LTD

TOWER CRANE QTZ型130tm  
(R70/15B)



Autodesk

Autodesk

Autodesk



塔身截面 Mast 2mx2m

40-70m

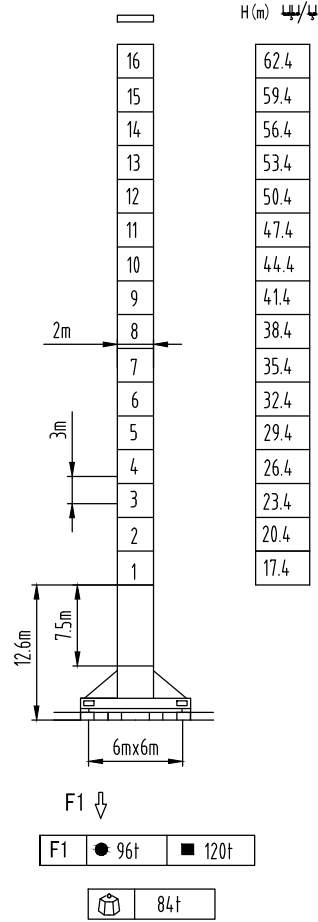
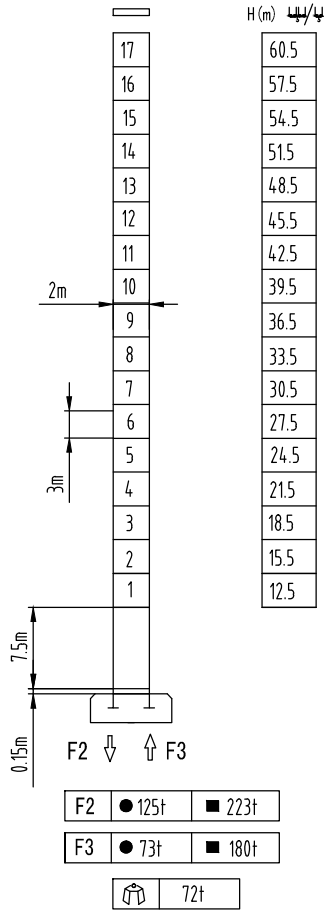

固定式附着高度 Anchoring height of stationary crane

★ 紧固附着框 Anchorages tightened

△ 放松附着框 Anchorages released

如需达到更高的高度, 请与我们联系。For greater heights, consult us.

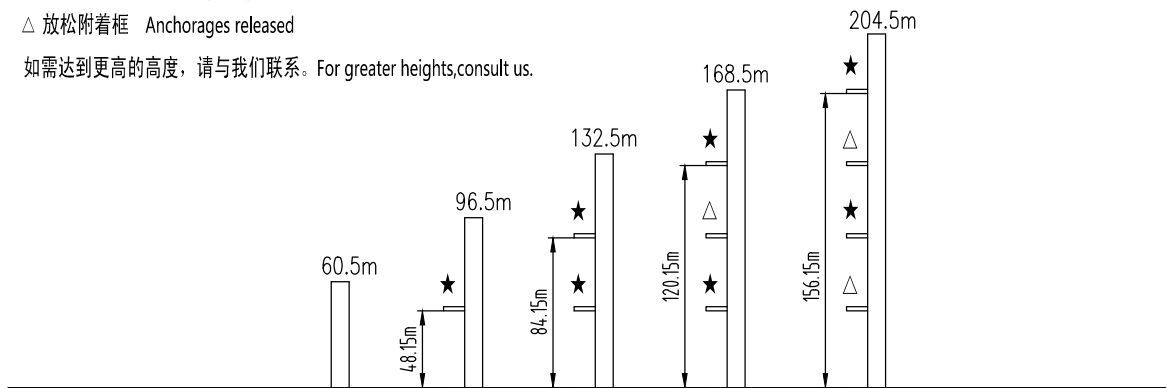

载荷特性 Load diagrams

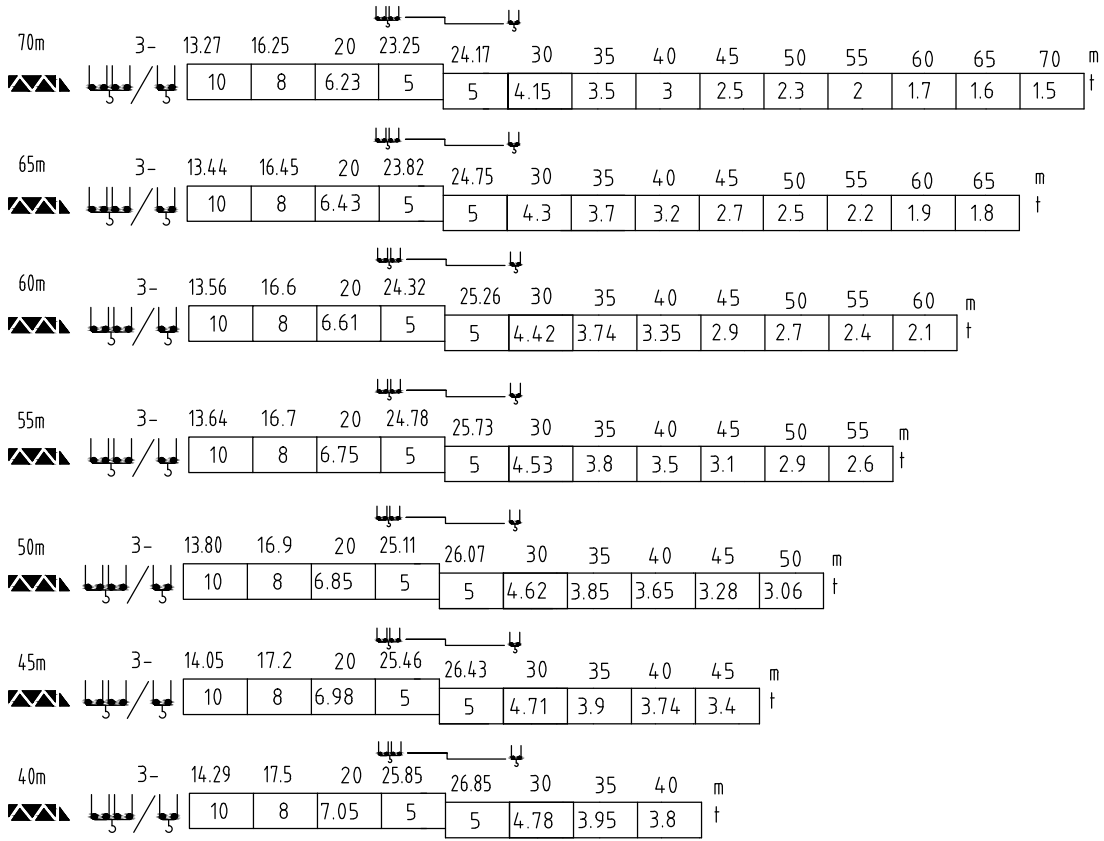

$\downarrow / \downarrow$  标准小车可使用 2/4 倍率绳 standard trolley 2/4 fall.  
 使用四倍率时, 应从二倍率的载荷中减去 0.35t  
 When using  $\downarrow / \downarrow$  subtract 0.35t from the loads  $\downarrow$

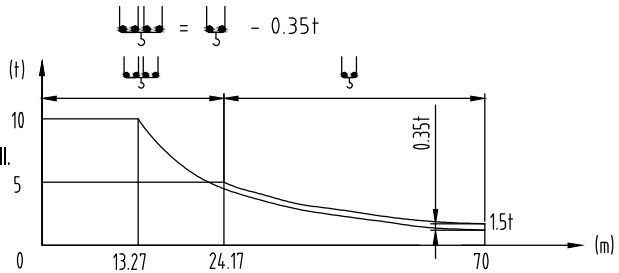

内爬塔机 Climbing crane

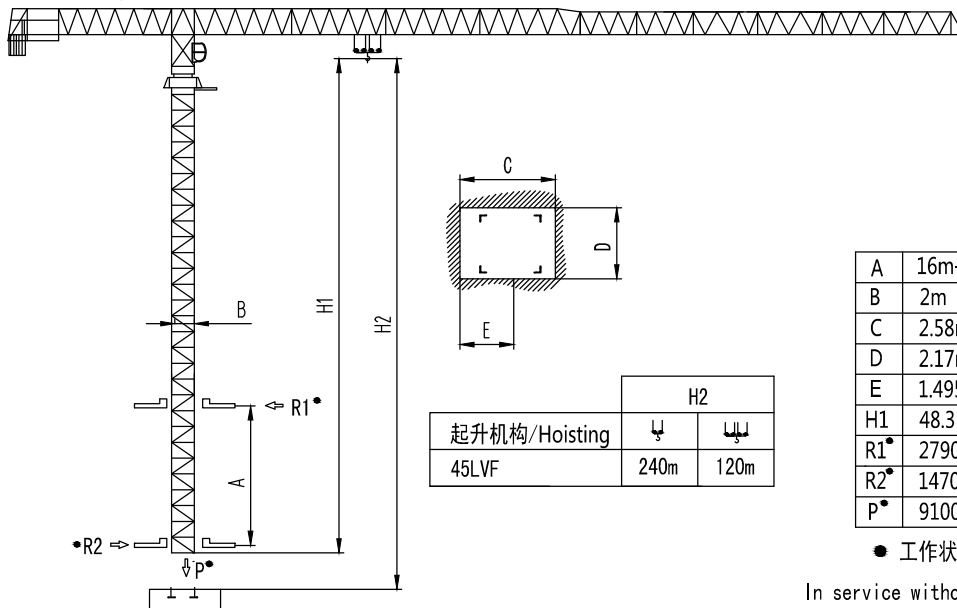

\* 工作状态无系数

In service without coefficient

# Autodesk

外形尺寸重量表 Dimensions weights

塔机回转部分 Slewing		L(m)	l(m)	h(m)	Kg	
平衡臂 Counter-jib		19.34	3.38	2.39	7321	
塔头 Cat-head		3.99	2.84	5.17	4175	
回转机构 Slewing mechanism		2.61	2.61	2.15	5628	
起重臂节 Jib section		1 2 3	10.33 10.29 10.27	1.41 1.41 1.41	2.33 2.29 2.26	2721 2272 1580
起重臂节 Jib section		4	10.25	1.41	2.25	1311
起重臂节 Jib section		5(1) 5(2) 6(1) 6(2) 7(1) 7(2)	5.26 5.23 5.21 5.17 5.14 5.14	1.41 1.41 1.41 1.41 1.41 1.41	1.63 1.63 1.58 1.58 1.55 1.55	662 658 435 421 375 367
变幅小车 Trolley		2.41	1.61	0.92	432	
吊钩滑轮组 Hook assembly		1.43	0.2	1.72	257	

# Autodesk

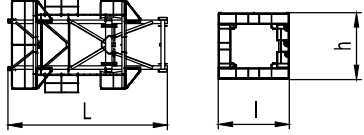
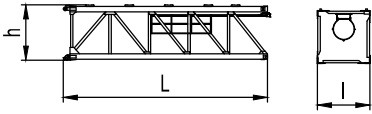
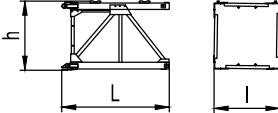
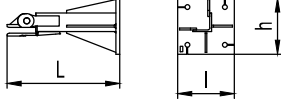
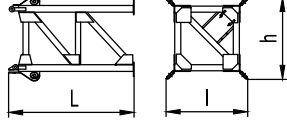
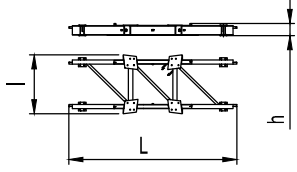
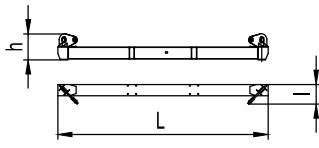
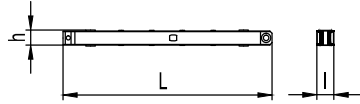
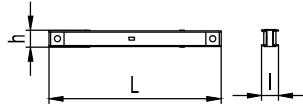
顶升装置 Telescoping equipment		L(m)	l(m)	h(m)	Kg
顶升套架 Telescopic cage		7.26	4.3	4.05	4288
塔身部分 Mast		L(m)	l(m)	h(m)	Kg
基础节 Basic mast		7.76	2.0	2.1	3790
标准节 Standard mast		3.28	2.0	2.1	1577
底部 Base		L(m)	l(m)	h(m)	Kg
固定支脚 Fixing angles		1.2	0.6	0.6	295
底架塔节 Chassis-mast		3.80	2.50	2.50	3780
底架纵梁 Side member		7.14	2.49	0.54	2140
底架横梁 Traverse		6.38	0.58	0.81	1500
底架撑杆 Brace rod		4.45	0.34	0.37	620
底架水平杆 Horizontal member		2.44	0.22	0.24	205

# Autodesk

机构特性 Mechanisms specification														Kw	
起升 Hoisting		45LVF	m/min	0-5.4	0-22.5	0-45	0-67.5	0-90	0-2.7	0-11.2	0-22.5	0-33.7	0-45	500	45
		t	5	5	5	2.5	1.25	10	10	10	5	2.5			
变幅 Trolleying		4TVF	m/min	0-55									4		
回转 Slewing		5.5SVF	r/min	0-0.8									5.5x2		
		120SVT											120Nx2		
行走 Travelling		4TRVF	m/min	0-12									4x4		
电源		Power Supply		380V 50Hz /440V 60Hz											
KVA 供电容量		Necessary Electric Power		70KVA											

平衡臂配重  
Counter-jib ballast

		(t)
70m	20.2m	14.04
65m	20.2m	12.85
60m	20.2m	11.66
55m	20.2m	10.76
50m	20.2m	9.82
45m	20.2m	7.9
40m	20.2m	6.25

可变换的其它安装方式  
Mounting possibilities

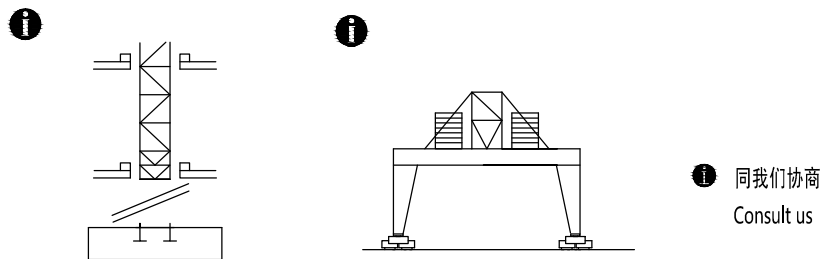

F 反力	● 工作状态	In service	⊕ 自重	不带载荷及配重, 最大臂长及标准高度时的自重.
Reactions	■ 非工作状态	Out of service	Self-load	Without load and counter-weight with longest jib and standard height