

OWNER'S GUIDE

SS5 STEPPER SERVO MOTOR DRIVER



©2020 by I.CH Motion Co.,Ltd..
All Rights Reserved

TECHNICAL DOCUMENT

Content

1. Introduction	3
2. Feature	3
3. Specification	4
4. Connections	5
Power Connector	6
Encoder Signal Connector	6
Control Signal Connector	6
Output Signal Connector	7
Control Signal Input Example Follow	7
ALM/INPOS Output diagrams follow	8
5. Switch Selection	9
Running Current	9
Microstepping	10
Self Test	10
Control Mode	10
6. Auto Tunning	10
7. Status Indicator	11
8. Mechanical Outline	12
9. Safety Precautions	13

Note:if you have any problems,please
email sales@ichmo.com to to contact us.



TECHNICAL DOCUMENT

1. Introduction

Thanks for choosing the SS serial motor drive. The CL5 is a new digital step servo motor drive based on a 32-bit DSP with advanced control algorithm. It brings a unique level of system smoothness, providing optimum torque and nulls mid-range instability. Motor self-test and parameter auto-tuning technology offers optimum responses with different motors and easy-to-use. The motors can run with much smaller noise, less heat, smoother movement.

2. Feature

- Brand new 32-bit DSP
- 16 settings of microstep resolution
- Servo control algorithm, accurate speed position control and good responsiveness
- Minimize heat generation by adjusting current in real time based on load
- Auto Set up motor parameters
- Step&Direction/CW&CCW pulse
- 1Mhz digital filter for high speed inputs
- Self Test-the drive will perform a 2rev,3rps,CW/CCW move test

TECHNICAL DOCUMENT

3. Specification

Parameters	Min	Typical	MAX	Unit
Supply voltage	24	-	75	VDC
Output current (Peak)	1.0	-	9.8	A
Control signal input current	6	10	15	mA
STEP/DIR Input Signal Voltage	4.0	5.0	28.0	VDC
Step Frequency	2	-	1M	Hz
STEP Minimum Pulse Width High and Low	250	-	-	Ns
DIR Minimum Pulse Width	50	-	-	us
Drive initialization time	-	-	2	S

TECHNICAL DOCUMENT

4. Connections

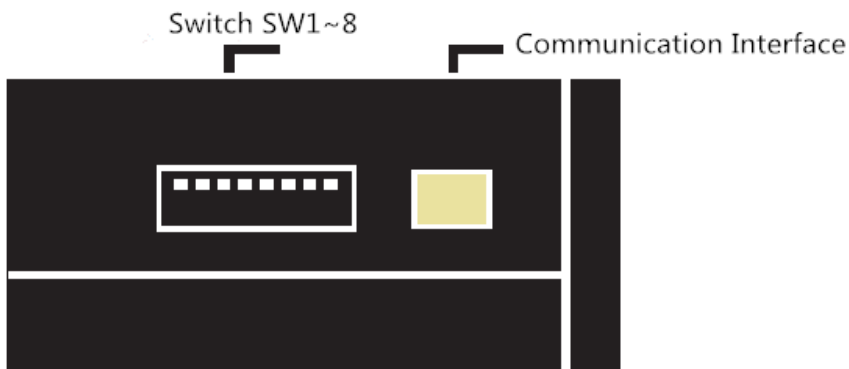
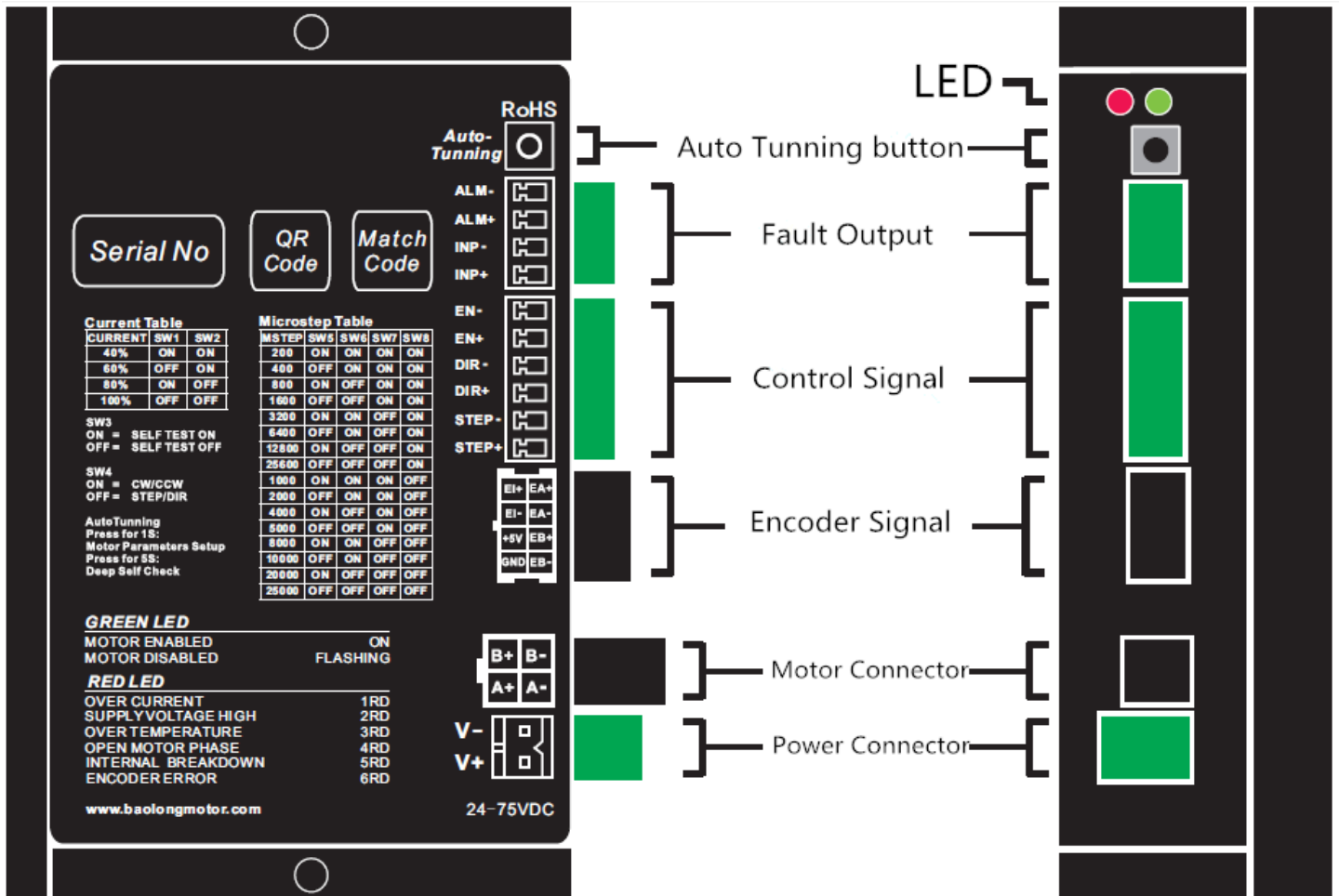

TECHNICAL DOCUMENT

Power Connector

Pin	Details
V+	24~75VDC input positive
V-	24~75VDC input negative
A+,A-	Motor phase A
B+,B-	Motor phase B

Encoder Signal Connector

Pin	Details
+5V	Encoder power supply interface
GND	
EA+	Encoder A phase differential input
EA-	
EB+	Encoder B phase differential input
EB-	
EI+	Encoder I phase differential input
EI-	

Control Signal Connector

Pin	Details
STEP+	In step&direction mode, this input represents pulse signal, each falling edge active; 5-28V when PUL-HIGH, 0-0.5V when PUL-LOW. In CW&CCW mode, this input represents clockwise (CW) pulse. For reliable response, pulse width should be longer than 1.5 μ s.
STEP-	
DIR+	In step&direction mode, this signal has low/high voltage levels, representing two directions of motor rotation; In CW&CCW mode, this signal is counter-clock (CCW) pulse. For reliable motion response, DIR signal should be ahead of PUL signal by 5 μ s at least. 5-24V when DIR-HIGH, 0-0.5V when DIR-LOW.
DIR-	
EN+	The EN input enables or disables the drive amplifier. It is an optically isolated input that accepts a 5 to 24 volt single-ended or differential signal. The maximum voltage that can be applied to the input is 28V. When EN input is closed, the drive amplifier is deactivated, all the MOSFETs will shut down, and the motor will be free. When EN input is open, the drive is activated.
EN-	

TECHNICAL DOCUMENT

Output Signal Connector

Pin	Details
INP+	In-position signal, optocoupler isolated OC output, maximum withstand voltage 30VDC, maximum saturation current 100mA, output optocoupler does not conduct when the motor does not go to the target position
INP-	
ALM+	Alarm signal, optocoupler isolated OC output, maximum withstand voltage 30VDC, maximum saturation current 100mA, output optocoupler does not conduct when the drive is working normally
ALM-	

Control Signal Input Example Follow

Difference

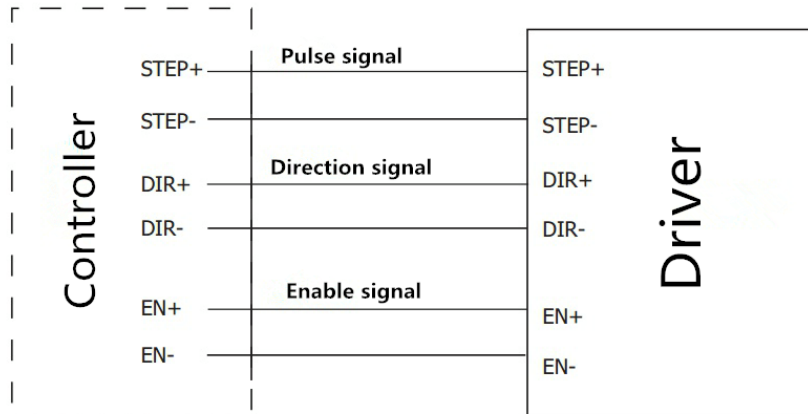

Common anode

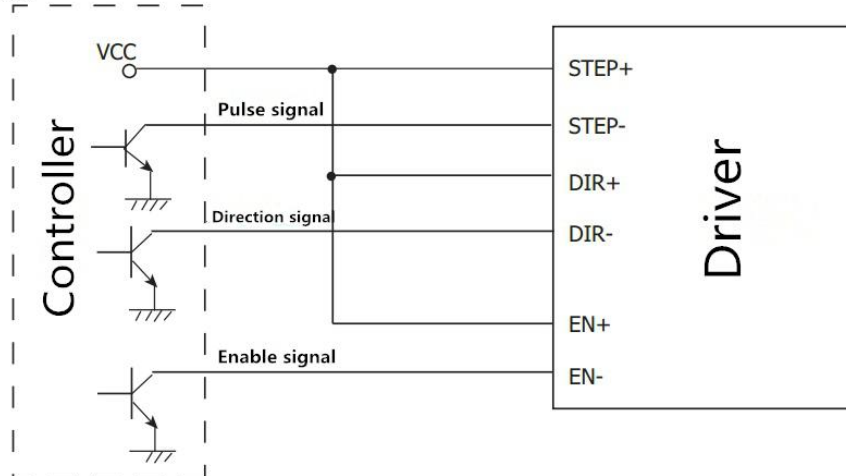

TECHNICAL DOCUMENT

Common cathode

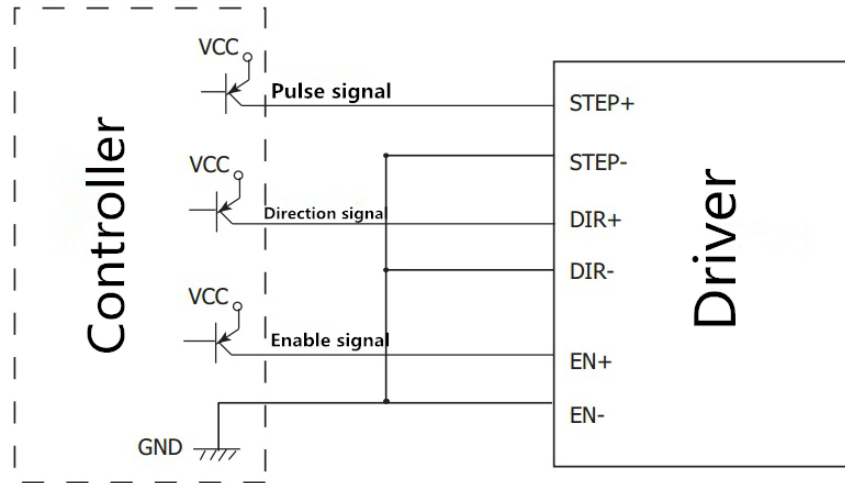

ALM/INPOS Output diagrams follow

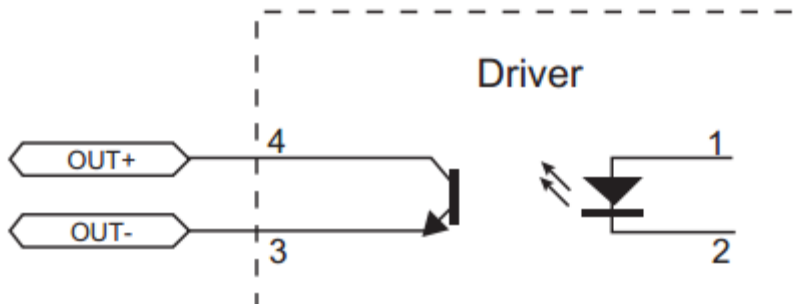

TECHNICAL DOCUMENT

5. Switch Selection

The SS5 drive uses an 8-bit DIP switch to set the subdivision accuracy, dynamic current, self-test function and pulse mode selection. The detailed description is as follows:

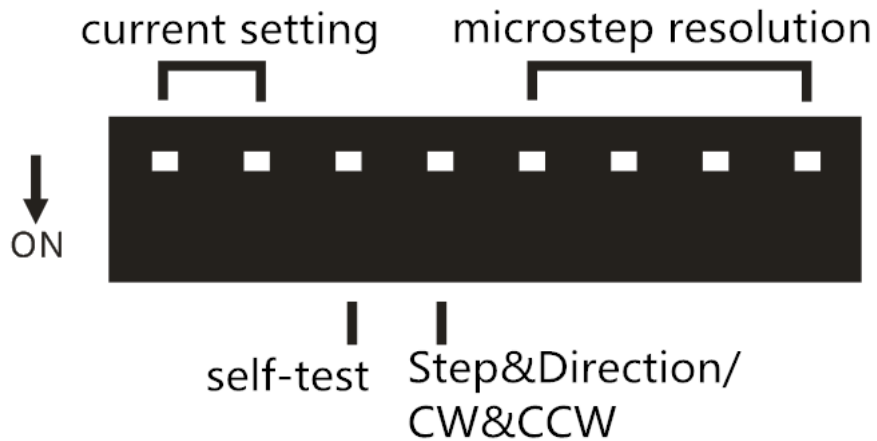

Running Current

After the drive is matched with the motor model, the running current dialing can set the actual output current to be 40%~100% of the rated current of the motor.

Rated current	SW1	SW2
40%	ON	ON
60%	OFF	ON
80%	ON	OFF
100%	OFF	OFF

TECHNICAL DOCUMENT

Microstepping

step/rev	SW5	SW6	SW7	SW8
200	ON	ON	ON	ON
800	ON	OFF	ON	ON
1600	OFF	OFF	ON	ON
3200	ON	ON	OFF	ON
6400	OFF	ON	OFF	ON
12800	ON	OFF	OFF	ON
25600	OFF	OFF	OFF	ON
1000	ON	ON	ON	OFF
2000	OFF	ON	ON	OFF
4000	ON	OFF	ON	OFF
5000	OFF	OFF	ON	OFF
8000	ON	ON	OFF	OFF
10000	OFF	ON	OFF	OFF
20000	ON	OFF	OFF	OFF
25000	OFF	OFF	OFF	OFF

Self Test

Setting switch SW3 to ON after the drive is powered up will cause the drive to perform a self test move of 2 revolutions both CW and CCW at 3rps. Setting switch SW9 to OFF disables this feature.

Control Mode

SW4 can set the mode of the control signal. When SW4 is OFF, the host computer needs to provide a pulse signal with one direction signal. When SW10 is ON, two pulses can be used to control the forward and reverse rotation of the motor. At this time, the pulse input to the STEP terminal controls the movement of the motor in the CW direction, and the pulse input to the DIR controls the movement of the motor in the CCW direction.









6. Auto Tunning

The Auto Tunning button is used to match the motor to the drive. Under normal circumstances, the motor and the drive have been matched one-to-one, and the customer does not need to match the motor and the drive.

TECHNICAL DOCUMENT

7. Status Indicator

The green LED is the enable indicator. When the motor is enabled, the LED is always on; when the motor is not enabled, the LED is blinking. The red LED is a fault indicator. When a fault occurs, the indicator flashes in a cycle; when the fault is cleared by the user, the red LED is always off. The number of red LED flashes represents different fault information, as shown in the following table:

Alarm code		Details
	Long green light	Drive enable
	Flashing green light	Drive disable
	Red light off	The drive is normal
	Red light flashes once	Drive overcurrent
	Red light flashes 2 times	Power supply voltage is too high
	Red light flashes 3 times	Drive over temperature
	Red light flashes 4 times	Motor phase line open
	Red light flashes 5 times	Drive internal fault
	Red light flashes 6 times	Encoder failure

TECHNICAL DOCUMENT

8. Mechanical Outline

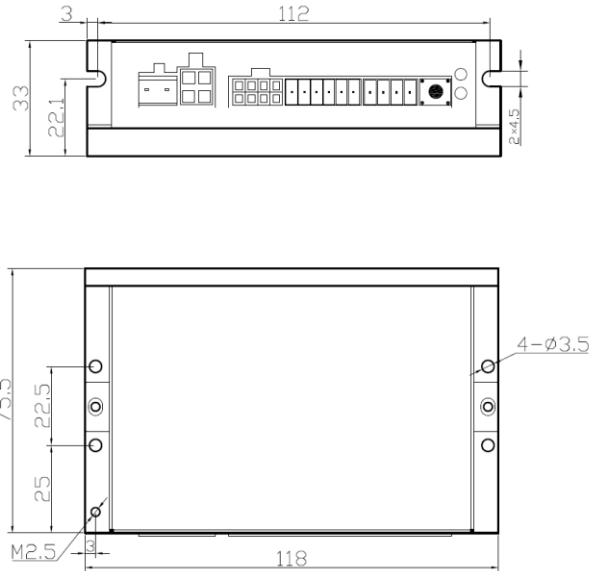

* The amplifiers in the drive generate heat. To operate the drive continuously at maximum power forced air cooling, as from a fan, should be provided. Never use the drive in a space where there is no air flow or where other devices can cause the surrounding air to be more than 40 °C. Never put the drive where it can get wet or where metal particles can fall into it.

TECHNICAL DOCUMENT

9. Safety Precautions

The precautions described below are intended to prevent the occurrence of danger or injury to users and other personnel and to use the product correctly. Please read and understand these precautions thoroughly before using this product.

- If the drive is accidentally damaged during operation, the company is only responsible for the repair and replacement of the drive within the warranty.
- The company does not bear the loss of control or casualties and property damage caused by accidental damage to the drive.
- Do not use the product with flammable materials when exposed to explosive, flammable, corrosive gases or water splashes or in a nearby location. Doing so may result in fire, electric shock or personal injury.
- Only qualified personnel should be allowed to install, connect, operate and perform inspection/exclusion of product failures. Handling of unqualified personnel may result in fire, electric shock, personal injury or equipment damage.
- Do not move, install, connect, or inspect the product while the drive is powered, and turn off the power when performing these operations. Failure to follow these instructions may result in electric shock.
- Do not use non-electromagnetic brakes in vertical applications. If the drive's protection function is activated, the motor may not stop and the moving parts of the device may fall, resulting in personal injury or equipment damage.
- Always keep the drive's power supply voltage below the rated value. Failure to do so may result in fire or damage to the drive.
- Always turn off the power before performing maintenance/inspection. Failure to do so may result in electric shock.
- Do not touch the connection terminals on the drive immediately after turning off the power (within 30 seconds, or until the power LED is turned off). Residual voltage may cause electric shock.
- Regularly check the dust accumulated in the open part of the cleaning drive. Accumulated dust can cause a fire.
- Do not disassemble or repair the motor and drive. Doing so may result in electric