

**SANJIU COOLING EQUIPMENT  
A TRUSTED BUSINESS PARTNER!**

**SANJIU  
COOLING**

**Professional  
Cooling Equipment & Solutions**



S  
A  
N  
J  
I  
U

WUXI SANJIU COOLING EQUIPMENT CO., LTD.

101 XINJIN ROAD, JIANGSU PROVINCE, PRC.

TEL: +86-510-85312176 FAX: +86-510-85312676



**CATALOGUE 2017**

Products can be modified without public notice.  
All copy rights reserved. Edition 2017.0



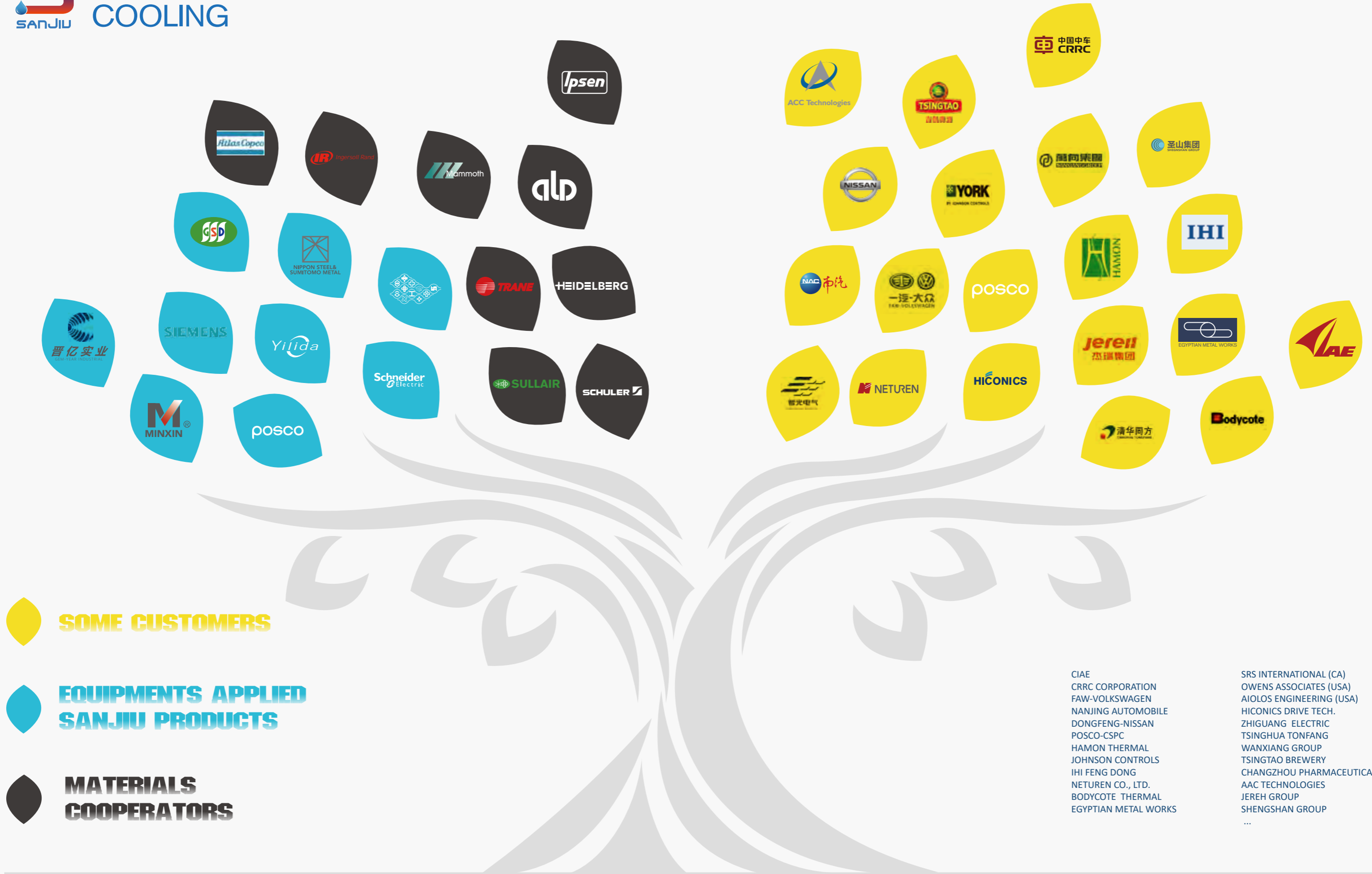

**SOME CUSTOMERS**

**EQUIPMENTS APPLIED  
SANJIU PRODUCTS**

**MATERIALS  
COOPERATORS**

- CIAE
- CRRC CORPORATION
- FAW-VOLKSWAGEN
- NANJING AUTOMOBILE
- DONGFENG-NISSAN
- POSCO-CSPC
- HAMON THERMAL
- JOHNSON CONTROLS
- IHI FENG DONG
- NETUREN CO., LTD.
- BODYCOTE THERMAL
- EGYPTIAN METAL WORKS

- SRS INTERNATIONAL (CA)
- OWENS ASSOCIATES (USA)
- AIOLOS ENGINEERING (USA)
- HICONICS DRIVE TECH.
- ZHIGUANG ELECTRIC
- TSINGHUA TONFANG
- WANXIANG GROUP
- TSINGTAO BREWERY
- CHANGZHOU PHARMACEUTICAL
- AAC TECHNOLOGIES
- JEREH GROUP
- SHENGSHAN GROUP
- ...

# ABOUT SANJIU

Share Advantages for Value Increase!

SANJIU Cooling is a professional manufacturer of cooling and heat exchange equipment, with advantages over cooling towers for water and other process fluids cooling of a wide range of applications.

The company is devoted to research, design, manufacturing, solutions, distribution and service of both standard and customized cooling equipment. The products have been exported widely to America, Canada, Australia, Chile, Russia, Mongolia, Venezuela, Croatia, Egypt, Jordan, Indonesia, Vietnam, India, etc., with representatives and agents overseas.

With joint efforts of Jiang Nan University, we have set up a R&D center for integrated water cooling solutions, and an advanced testing platform under directives of CTI. Our products are of high efficiency, superior corrosion resistance, low noise, environmental protection, easy installation, simple operation, and stable performance in long years' heavy duty service life.

The products are widely applied in various of fields, to cool circulating water, oil or other process fluid for HVAC System, Compressors, Data Centers, Ground Source Heat Pumps, Melting/ Vacuum/ Multi-crystal Furnaces, Induction Heaters, Printing Lines, Injection Machines, Casting Machines, Hydraulic Stations, Power Generators, Transformers, Converters, Refrigerators, Food and Chemical Production Lines, etc.

Our active staff is keen to share the knowledge and experiences with all customers and users, and we are always ready to provide the most competitive cooling equipment& solutions with continuous supports in the future!



**GHM Series Evaporative Cooling Tower**  
Closed Circuit, Cross Flow



**GTM Series Evaporative Cooling Tower**  
Closed Circuit, Counter Flow



**GOM Series Steel Open Tower**  
Open Circuit, Cross Flow



**GKM Series Dry Cooler**



**GZM Series Evaporative Condenser**

## ➤ CATALOGUE

General Introduction	01
-----	
-GHM Cross Flow Series	05
-GTM Counter Flow Series	07
-GOM Open Loop Series	09
-GKM Dry Cooling Series	11
-GZM Evaporative Condensing Series	13
-----	
Product Features	15
Product Configurations	17
Customized Solutions	23
Typical Projects Reference	25
Technical Support	35



Manufacturing First Grade Cooling Towers and Equipment with Advanced Technology & Facilities!

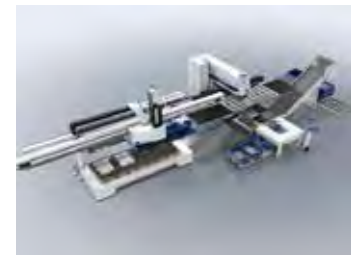

## PRODUCTION

Standard production facilities with professional and experienced workers, strictly operated according to ISO9001, ISO14000, and 6S management.



## QUALITY CONTROL

Thermodynamic test station designed and developed with joint efforts of Jiang Nan University, used to simulate the different working conditions, to carry out type tests according to CTI directives, ensure the heat exchange capacity and general performance of each tower made by Sanjiu Cooling.

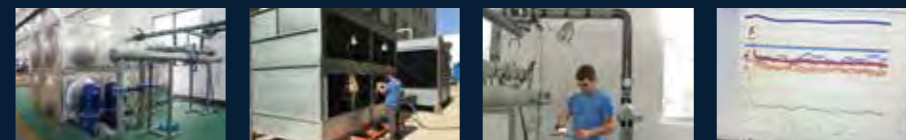

Strict Testing System According to CTI Standards.

# GHM SERIES

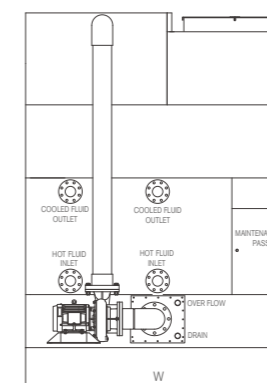
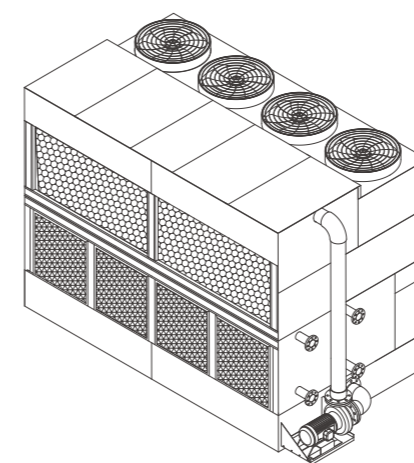

VIEW 1

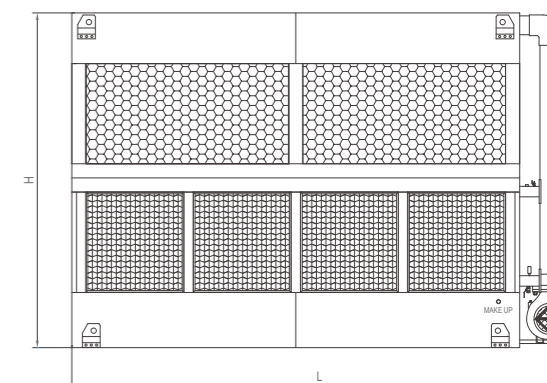

VIEW 2

## CLOSED CROSS FLOW COOLING TOWER

**GHM** Series are of capacities from 30 to 366 nominal tons, can work in series as a group for larger capacities. Casing made in special alloy coated steel or stainless steel, Heat exchange coils made in stainless steel or red copper, Wet deck fills made in PVC. All raw materials are of high industrial grade, with superior corrosion resistant features. GHM towers are designed of high efficiency but lower initial and long term costs, easy and economical installation and maintenance. The towers dimensions can be customized to suit standard containers or particular project conditions. GHM towers are widely applied in different fields, to cool circulating water, oil or other process fluid for HVAC System, Compressors, Furnaces, Data Centers, Ground Source Heat Pumps, Power Generators, Transformers, Converters, Refrigerators, Food and Chemical Production Lines, etc.

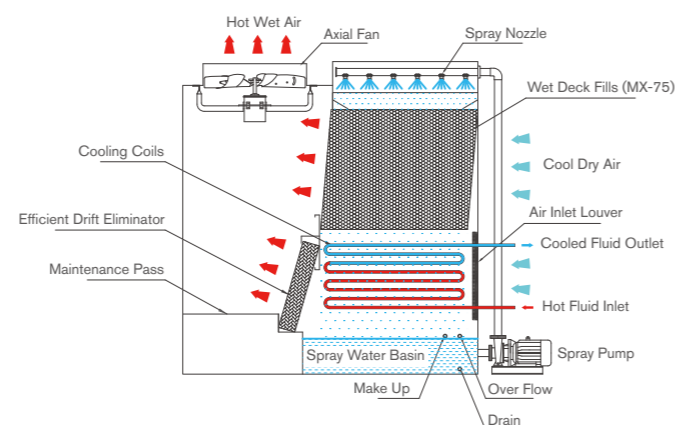

### WORKING THEORY

GHM series belong to induced draft type cross flow cooling towers. During the working process, dry cool air is inlet through wide louvers on one side of the tower, then directed through the heat exchange coils and wet deck fills across the spray water, becoming wet hot air, eventually induced draught out of the tower into the atmosphere by the fans on the top. In this process, a part of heat from the fluids inside the closed loop is transferred efficiently, and removed continuously.

Model No.	Nominal Tons	Fan		Spray Pump		Connecting Pipe (mm)			Overall Dimensions(mm)			Weight	
		Power (kW)	Air Volumn (m <sup>3</sup> /s)	Power (kW)	Flow Rate (T/h)	Inlet/Outlet	Make Up	Drainage	L	W	H	Net (kg)	Operation (kg)
GHM-225	30	1.1×2	3.7×2	1.5	45	DN80	DN25	DN40	2540	1940	2200	1020	1820
GHM-230	37	1.1×2	3.7×2	1.5	45	DN80	DN25	DN40	2960	1940	2200	1050	2020
GHM-235	43	1.1×2	3.7×2	1.5	45	DN80	DN25	DN40	2960	1940	2200	1100	2100
GHM-340	49	1.1×3	3.7×3	2.2	60	DN80	DN25	DN40	3360	1940	2200	1310	2540
GHM-350	61	1.1×3	3.7×3	2.2	60	DN80×2	DN25	DN40	3760	2240	2200	1450	3080
GHM-365	79	1.5×3	5.1×3	2.2	60	DN80×2	DN25	DN40	3360	1940	2730	1520	3200
GHM-380	98	1.5×4	5.1×4	2.2	114	DN80×2	DN25	DN40	4220	2240	2680	2050	4920
GHM-390	110	1.5×4	5.1×4	2.2	114	DN80×2	DN25	DN40	4220	2240	2680	2100	5000
GHM-3100	122	1.5×4	5.1×4	2.2	114	DN80×2	DN25	DN40	4220	2240	2840	2150	5100
GHM-3110	134	1.5×4	5.1×4	2.2	114	DN80×2	DN25	DN40	4220	2240	2840	2250	5250
GHM-5125	152	1.5×4	5.1×4	3.7	140	DN100×2	DN40	DN40	4740	2240	2910	2800	6800
GHM-5150	183	2.2×4	6.3×4	3.7	140	DN100×2	DN40	DN40	5440	2240	2910	3200	7820
GHM-5175	213	2.2×4	6.3×4	3.7	140	DN125×2	DN40	DN40	5440	2240	2910	3300	8000
GHM-7200	244	4×4	16.7×4	5.5	160	DN125×2	DN40	DN40	5840	2900	3260	5000	9000
GHM-7225	274	4×4	16.7×4	5.5	160	DN125×2	DN40	DN40	5840	2900	3470	5500	10000
GHM-7250	305	4×4	16.7×4	5.5	160	DN150×2	DN40	DN40	6420	2900	3470	6500	11500
GHM-7275	335	4×4	16.7×4	5.5	160	DN150×2	DN40	DN40	6420	2900	3470	6800	11800
GHM-7300	366	4×4	16.7×4	5.5	160	DN150×2	DN40	DN40	6420	2900	3470	7000	12000

### NOTE

Nominal Tons are based upon temp. drop 35~29.5°C/ 95~85°F, WBT 25.5°C/ 78°F, and 0.681 m<sup>3</sup>/hr/ton.

# GTM SERIES

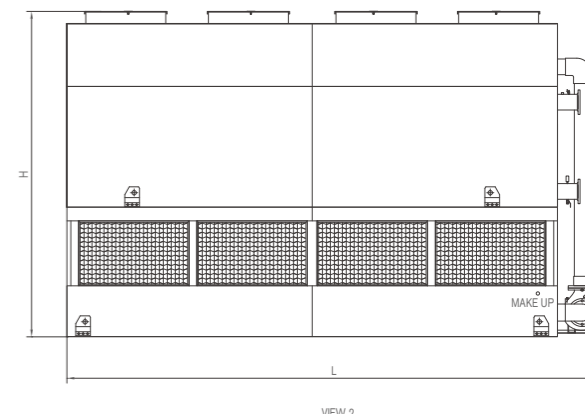
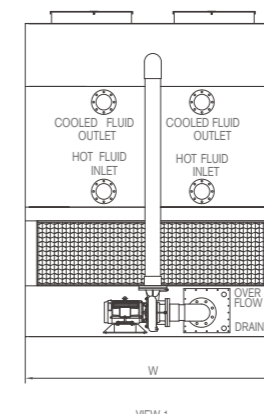
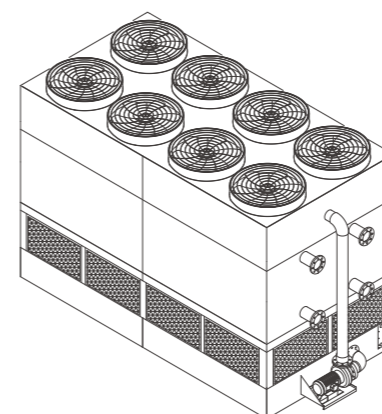

## CLOSED COUNTER FLOW COOLING TOWER

**GTM** Series are of regular capacities from 6 to 305 nominal tons. Casing made in special alloy coated steel or stainless steel, Heat exchange coils made in stainless steel or red copper. GTM Towers tend to be more compact, taking less installation space, working without any wet deck fill, more suitable to cool hot water of higher inlet temperature. The towers dimensions can be customized to suit standard containers or particular project conditions. GTM towers are widely applied in different fields, to cool circulating water, oil or other process fluid for Melting/ Vacuum/ Multi-crystal Furnaces, Induction Heaters, Compressors, Heat Pumps, Metal Parts Production Lines, Hydraulic Stations, Power Generators, Transformers, Converters, etc.

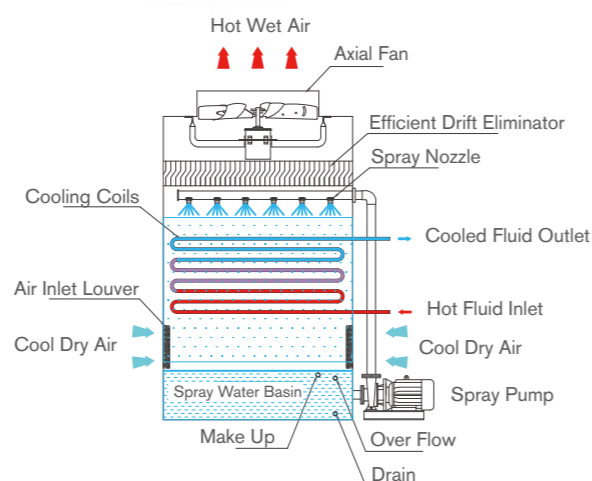

### WORKING THEORY

As counter flow towers, the dry cool air is inlet through louvers on both sides of the tower from the bottom, and drawn upwards passing a large heat exchange surface of the coils under the induced fans, against the spraying water in the opposite way, becoming hot wet air, induced draught out of the tower into the atmosphere by the fans on the top. During this process, a part of the heat from the fluids inside the closed loop is transferred efficiently, and removed to the outside environment.

Model No.	Nominal Tons	Fan		Spray Pump		Connecting Pipe(mm)			Overall Dimensions(mm)			Weight	
		Power (kW)	Air Volumn (m <sup>3</sup> /s)	Power (kW)	Flow Rate (T/h)	Inlet/Outlet	Make Up	Drainage	L	W	H	Net (kg)	Operation (kg)
GTM-15	6	0.55	2.4	0.75	20	DN50	DN25	DN40	2200	1000	1830	450	700
GTM-110	12	0.55	2.4	0.75	20	DN50	DN25	DN40	2400	1000	1900	490	800
GTM-115	18	0.55×2	2.4×2	0.75	20	DN65	DN25	DN40	2300	1020	1830	460	1000
GTM-120	24	0.55×2	2.4×2	0.75	20	DN65	DN25	DN40	2300	1020	1900	500	1050
GTM-225	30	0.55×2	2.4×2	1.5	45	DN80	DN25	DN40	2860	1240	2050	730	1650
GTM-230	37	1.1×2	3.7×2	1.5	45	DN80	DN25	DN40	2860	1240	2180	830	1760
GTM-235	43	1.1×2	3.7×2	1.5	45	DN65×2	DN25	DN40	2860	1240	2420	1050	2030
GTM-340	49	1.5×2	5.1×2	2.2	60	DN65×2	DN25	DN40	2860	1520	2440	1280	2500
GTM-350	61	1.5×2	5.1×2	2.2	60	DN80×2	DN25	DN40	2860	1520	2630	1370	2660
GTM-365	79	1.1×4	3.7×4	2.2	60	DN80×2	DN25	DN40	3200	1760	2630	1820	3460
GTM-370	85	1.1×4	3.7×4	2.2	114	DN80×2	DN25	DN40	3200	2120	2750	1930	3970
GTM-380	98	1.5×4	5.1×4	2.2	114	DN80×2	DN25	DN40	3200	2120	2750	2050	4000
GTM-390	110	1.5×4	5.1×4	2.2	114	DN80×2	DN25	DN40	3200	2120	2750	2150	4050
GTM-3100	122	1.5×4	5.1×4	2.2	114	DN80×2	DN25	DN40	3550	2120	2750	2330	4710
GTM-3110	134	1.5×6	5.1×6	2.2	114	DN80×2	DN25	DN40	4150	2120	2870	2650	5550
GTM-5125	152	1.5×8	5.1×8	3.7	140	DN100×2	DN40	DN40	4750	2120	2970	3100	6500
GTM-5150	183	1.5×8	5.1×8	3.7	140	DN100×2	DN40	DN40	5050	2120	3120	3500	7480
GTM-7175	213	1.5×8	5.1×8	5.5	160	DN125×2	DN40	DN40	5480	2120	3120	3800	8240
GTM-7200	244	1.5×8	5.1×8	5.5	160	DN125×2	DN40	DN40	5080	2620	3120	4800	9170
GTM-7225	274	1.5×8	5.1×8	5.5	160	DN125×2	DN40	DN40	5480	2620	3220	5600	11300
GTM-10250	305	1.5×10	5.1×10	7.5	240	DN150×2	DN40	DN40	6230	2620	3220	6000	12560

### NOTE

Nominal Tons are based upon temp. drop 35~29.5°C/ 95~85°F, WBT 25.5°C/ 78°F, and 0.681 m<sup>3</sup>/hr/ton.



# GOM SERIES

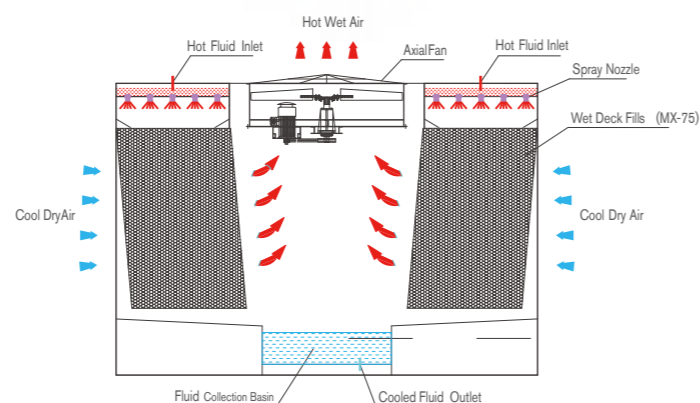

## OPEN COOLING TOWER

**GOM** Series cross flow steel open cooling towers are generally of higher capacities, can work in series as a group for large projects. Enclosure made in special alloy coated steel or stainless steel. GOM towers are of optimized firm structure, high efficiency, low drift rate, and anti blocking. The towers dimensions can be customized to suit standard containers or particular project conditions. GOM towers are widely applied in different fields, to cool circulating water for Melting Furnaces, Induction Heaters, Metal Parts Production Lines, Hydraulic Stations, Power Generators, and other utilities requiring massive cooling water, but not highly demanding on water quality. Initial invest in open towers is lower, but water consumption rate is higher comparing to closed loop cooling towers.

### WORKING THEORY

In GOM open cooling towers, the hot water is inlet to the water distribution basin on the top of the tower firstly, and spread onto the extensive surface of the wet deck fills after flowing through the spreading holes by gravity. Meanwhile the dry cool air is inlet through the side louvers of the tower, passing the fills across the water falls. During this process, a part of water is evaporated, with heat removed. The wet hot air is induced draught out of the tower into the atmosphere by the fans on the top, while the cooled water is collected back to the bottom collection basin with the eliminator, flowing back to the equipment requiring cooling water.

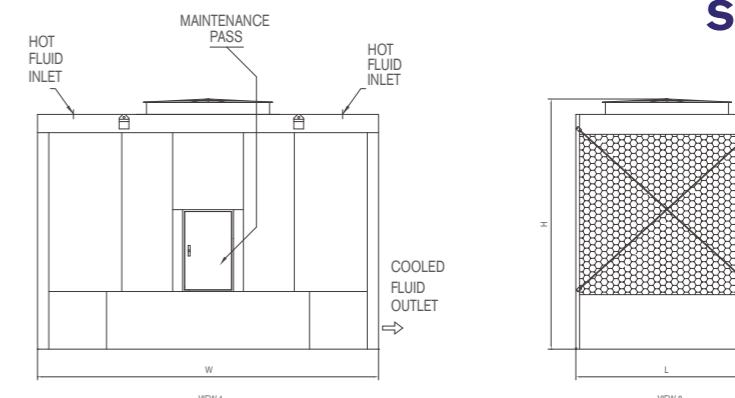
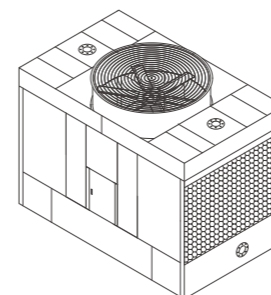

Model No.	Nominal Tons	Fan power (kW)	Connecting Pipe (mm)					Overall Dimensions(mm)			Weight		
			Inlet	Outlet	Make Up	Overflow	Drain	L	W	H	Net (kg)	Operation (kg)	
GOM0109	S-1	136	3.7	DN150×2	DN150	DN25	DN50	DN50	1980	3910	3200	1800	3500
	Q-1	156	5.5	DN150×2	DN150	DN25	DN50	DN50	1980	3910	3200	1800	3500
	P-1	171	7.5	DN150×2	DN150	DN25	DN50	DN50	1980	3910	3200	1800	3500
GOM0115	Q-1	208	5.5	DN150×2	DN150	DN25	DN50	DN50	2550	4300	3220	2150	4600
	P-1	231	7.5	DN150×2	DN150	DN25	DN50	DN50	2550	4300	3220	2150	4600
	O-1	264	5.5	DN200×2	DN200	DN25	DN50	DN50	2550	5530	3730	3350	7100
GOM0215	P-1	291	7.5	DN200×2	DN200	DN25	DN50	DN50	2550	5530	3730	3350	7100
	O-1	322	11	DN200×2	DN200	DN25	DN50	DN50	2550	5530	3730	3350	7100
	N-1	363	15	DN200×2	DN200	DN25	DN50	DN50	2550	5530	3730	3350	7100
	M-1	383	18.5	DN200×2	DN200	DN25	DN50	DN50	2550	5530	3730	3350	7100
GOM0120	Q-1	312	5.5	DN200×2	DN200	DN40	DN65	DN50	3010	6070	3750	3850	8500
	P-1	347	7.5	DN200×2	DN200	DN40	DN65	DN50	3010	6070	3750	3850	8500
	O-1	395	11	DN200×2	DN200	DN40	DN65	DN50	3010	6070	3750	3850	8500
	N-1	433	15	DN200×2	DN200	DN40	DN65	DN50	3010	6070	3750	3850	8500
GOM0126	M-1	460	18.5	DN200×2	DN250	DN40	DN65	DN50	3010	6070	3750	3850	8500
	L-1	481	22	DN200×2	DN250	DN40	DN65	DN50	3010	6070	3750	3850	8500
	P-1	393	7.5	DN200×2	DN200	DN40	DN65	DN50	3620	6400	3750	4850	11200
	O-1	449	11	DN200×2	DN250	DN40	DN65	DN50	3620	6400	3750	4850	11200
GOM0132	N-1	490	15	DN200×2	DN250	DN40	DN65	DN50	3620	6400	3750	4850	11200
	M-1	529	18.5	DN200×2	DN250	DN40	DN65	DN50	3620	6400	3750	4850	11200
	L-1	560	22	DN200×2	DN250	DN40	DN65	DN50	3620	6400	3750	4850	11200
	K-1	610	30	DN200×2	DN250	DN40	DN65	DN50	3620	6400	3750	4850	11200
GOM0226	O-1	513	11	DN250×2	DN250	DN40	DN65	DN50	4230	6830	3750	5750	13600
	N-1	563	15	DN250×2	DN250	DN40	DN65	DN50	4230	6830	3750	5750	13600
	M-1	605	18.5	DN250×2	DN250	DN40	DN65	DN50	4230	6830	3750	5750	13600
	L-1	637	22	DN250×2	DN250	DN40	DN65	DN50	4230	6830	3750	5750	13600
GOM0326	K-1	700	30	DN250×2	DN300	DN40	DN65	DN50	4230	6830	3750	5750	13600
	J-1	753	37	DN250×2	DN300	DN40	DN65	DN50	4230	6830	3750	5750	13600
	O-1	555	11	DN250×2	DN250	DN50	DN65	DN65	3620	6830	4970	7250	15200
	N-1	608	15	DN250×2	DN250	DN50	DN65	DN65	3620	6830	4970	7250	15200
GOM0332	M-1	654	18.5	DN250×2	DN250	DN50	DN65	DN65	3620	6830	4970	7250	15200
	L-1	694	22	DN250×2	DN250	DN50	DN65	DN65	3620	6830	4970	7250	15200
	K-1	757	30	DN250×2	DN300	DN50	DN65	DN65	3620	6830	4970	7250	15200
	J-1	811	37	DN250×2	DN300	DN50	DN65	DN65	3620	6830	4970	7250	15200
GOM0332	N-1	658	15	DN250×2	DN250	DN50	DN65	DN65	3620	6830	5840	7950	16900
	M-1	703	18.5	DN250×2	DN300	DN50	DN65	DN65	3620	6830	5840	7950	16900
	L-1	741	22	DN250×2	DN300	DN50	DN65	DN65	3620	6830	5840	7950	16900
	K-1	805	30	DN250×2	DN300	DN50	DN65	DN65	3620	6830	5840	7950	16900
	J-1	857	37	DN250×2	DN300	DN50	DN65	DN65	3620	6830	5840	7950	16900
GOM0332	N-1	742	15	DN250×2	DN300	DN50	DN65	DN65	4230	6830	5840	8650	19400
	M-1	791	18.5	DN250×2	DN300	DN50	DN65	DN65	4230	6830	5840	8650	19400
	L-1	835	22	DN250×2	DN300	DN50	DN65	DN65	4230	6830	5840	8650	19400
	K-1	907	30	DN250×2	DN300	DN50	DN65	DN65	4230	6830	5840	8650	19400
	J-1	968	37	DN250×2	DN300	DN50	DN65	DN65	4230	6830	5840	8650	19400
I-1	1017	45	DN250×2	DN350	DN50	DN65	DN65	4230	6830	5840	8650	19400	

### NOTE

Nominal Tons are based upon temp. drop 35~29.5°C/ 95~85°F, WBT 25.5°C/ 78°F, and 0.681 m³/hr/ton.

# GKM SERIES

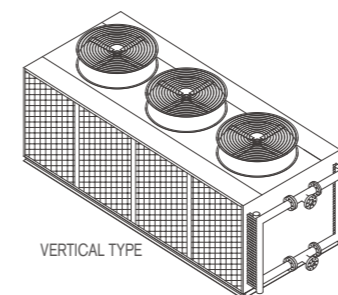

VERTICAL TYPE

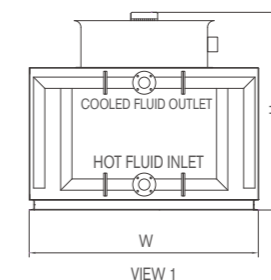

VIEW 1

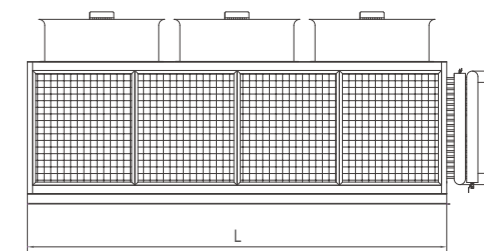

VIEW 2

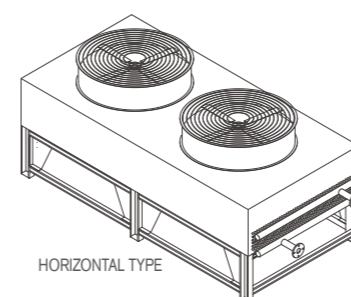

HORIZONTAL TYPE

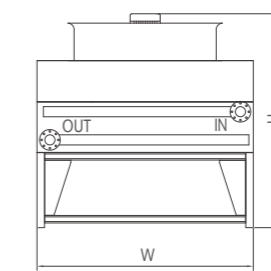

VIEW 1

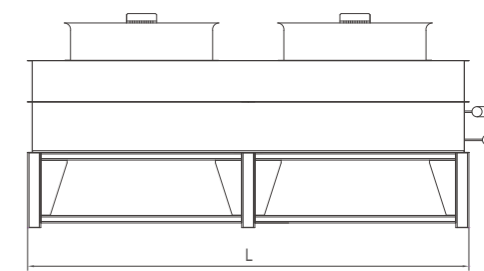

VIEW 2

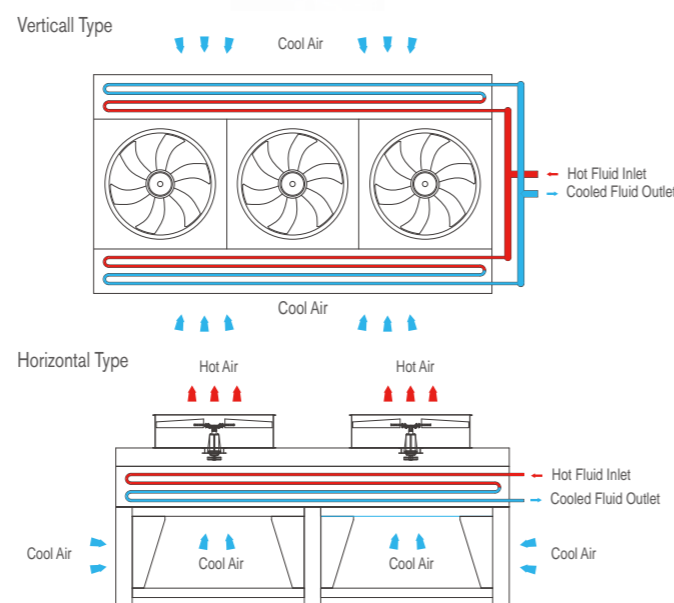

## DYR AIR COOLING TOWER

**GKM** Dry Cooling Series have been developed since 2012, with a wide range of cooling capacities. Enclosure made special alloy coated steel, or stainless steel optional. Heat exchange coils made in copper tube or stainless steel tubes fitted with aluminum or copper fins around the tubes. The fluid inlet and outlet are set on the same side, easy in installations. The overall dimensions can be tailor-made to suit standard containers or particular project conditions. GKM Towers are more widely applied to cool process fluids (water, oil, or gas) of generally higher temperature, such as for Air Compressors, Furnaces, Heaters, and other utilities in Gas Stations, Refinery Industries, etc., especially in the area short of water resources.

### WORKING THEORY

Dry cooling towers work without spray water. High volume of air is inlet continuously through the louvers, going through the large surface of heat exchange coils with intensive fins. Heat from the process fluid inside the coils is transferred to the high speed flowing air efficiently, and induced draught out of the tower into the atmosphere by the strong fans on the top.

Model No.	Nominal Tons	Fan		Water Inlet / Outlet	Overall Dimensions(mm)			Weight (kg)
		Power (kW)	Air Volum (m <sup>3</sup> /s)		L	W	H	
GKM-90H	16	6	15	DN65	3200	1240	2350	950
GKM-110H	20	9	18.3	DN65	3900	1240	2350	1050
GKM-135H	25	9	22.5	DN65	4200	1392	2350	1250
GKM-160H	30	12	26.7	DN65	4500	1544	2350	1500
GKM-185H	35	12	30.6	DN65	4700	1696	2350	1700
GKM-200V	40	16.5	33.3	DN80	4500	2200	2150	2200
GKM-220V	45	16.5	36.1	DN80	4500	2200	2260	2500
GKM-250V	50	16.5	41.7	DN80	4500	2200	2420	3000
GKM-280V	55	16.5	47.2	DN100	5000	2200	2500	3800
GKM-315V	60	22.5	52.8	DN100	5000	2200	2650	4300
GKM-355V	65	22.5	61.1	DN100	5400	2200	2650	4950
GKM-400V	75	22.5	66.7	DN100	5400	2200	2780	5250
GKM-450V	85	30	75	DN100	5500	2200	2920	5800
GKM-500V	94	30	83.3	DN100	5600	2200	2800	6500

### NOTE

Nominal Tons are based upon temp. drop 47~41°C / 117~106°F, DBT 35°C / 95°F.



# GZM SERIES

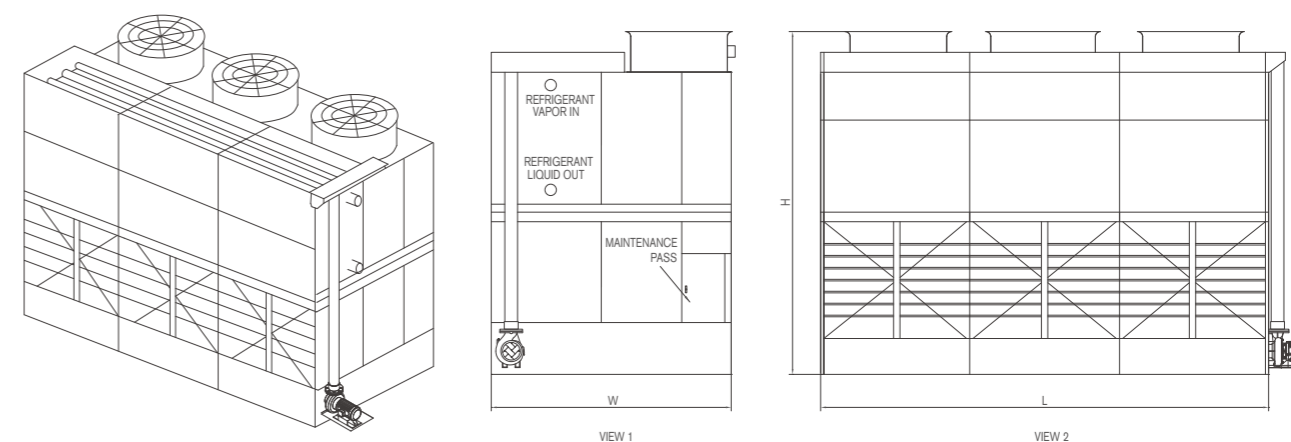

## EVAPORATIVE CONDENSER

**GZM** Series Evaporative Condensers are made in the same types of materials as GHM and GTM Series, and of similar working theory as a type of Evaporative Coolers, but designed dedicatedly to cool process fluids of refrigerant, of which the forms are changed during the process.

The equipment utilize the evaporation of partial spray water, to absorb the heat from the flowing gaseous refrigerant of high temperature inside the condensing coils, and cool the refrigerant from gaseous state to liquid form.

In a complete evaporative cooling system, compressor discharges high pressure evaporated refrigerant in gas form, which passes through the heat exchange coils of evaporative condenser, and exchanges heat with spray water outside the heat exchange coils. After entering heat exchange coils from upper inlet, gaseous refrigerant is gradually cooled to be liquid form from top down. The strong wind of fans makes spray water fully cover the

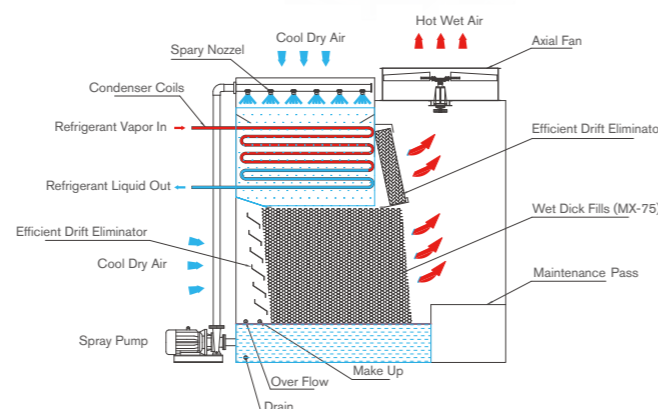

heat exchange surface of the coils evenly, and this tremendously increases the heat exchange efficiency. Partial calefactive spray water gets vaporized and takes away massive heat with the air flow. Small water drops in hot air are intercepted by high efficient drift eliminator, collected and fall back to wet deck fills together with hot spray water, then gets cooled by flowing air, eventually return to the spray water basin after temperature decreased. This whole process is recycling by the circulating pump, and the evaporated spray water is made up automatically by water level regulator.

Model No.	Nominal Tons	Fan		Spray Pump		Gas Inlet	Liquid Outlet	Overall Dimensions(mm)			Weight	
		Power (kW)	Air Volumn (m <sup>3</sup> /s)	Power (kW)	Flow Rate (T/h)			L	W	H	Net (kg)	Operation (kg)
GZM-100	100	1.1	3.9	0.75	16	DN40	DN32	1130	770	2800	500	970
GZM-115	115	1.5	5	0.75	16	DN40	DN32	1150	890	3025	600	1070
GZM-130	130	1.5	5	0.75	16	DN40	DN32	1150	890	3025	620	1100
GZM-145	145	1.5	5.6	0.75	16	DN40	DN32	1160	1050	3075	800	1280
GZM-160	160	1.5	5.6	0.75	16	DN40	DN32	1160	1050	3075	820	1300
GZM-180	180	2.2	6.9	0.75	16	DN80	DN80	1710	1125	3210	1150	1630
GZM-200	200	2.2	6.9	0.75	16	DN80	DN80	1710	1125	3210	1170	1650
GZM-220	220	3	7.5	0.75	16	DN80	DN80	1835	1220	3210	1250	1950
GZM-240	240	3	7.5	0.75	16	DN80	DN80	1835	1220	3210	1270	1970
GZM-280	280	3	8.9	0.75	16	DN80	DN80	1680	1220	3400	1200	1900
GZM-300	300	3	8.9	0.75	16	DN80	DN80	1680	1220	3400	1220	1920
GZM-320	320	4	11.1	0.75	16	DN80	DN80	1880	1250	3400	1400	2100
GZM-340	340	4	11.1	0.75	16	DN80	DN80	1880	1250	3400	1420	2120
GZM-360	360	4	12.5	0.75	22	DN80	DN80	2000	1350	3400	1650	2350
GZM-380	380	4	12.5	0.75	22	DN80	DN80	2000	1350	3400	1670	2370
GZM-400	400	4	12.5	0.75	22	DN80	DN80	2000	1350	3400	1690	2390
GZM-430	430	4	18.1	1.5	45	DN100	DN100	1830	2410	4300	2490	3830
GZM-475	475	4	18.1	1.5	45	DN100	DN100	1830	2410	4300	2700	4050
GZM-495	495	5.5	19.7	1.5	45	DN100	DN100	1830	2410	4300	2710	4060
GZM-550	550	4	17.6	2.2	75	DN100	DN100	1930	3010	4350	3310	4980
GZM-595	595	5.5	21.7	2.2	75	DN100	DN100	1930	3010	4350	3320	4990
GZM-670	670	5.5	21.7	2.2	75	DN100	DN100	1930	3010	4350	3700	5380
GZM-700	700	5.5	21.7	2.2	75	DN100	DN100	1930	3010	4950	3800	5890
GZM-735	735	7.5	24.2	2.2	75	DN100	DN100	1930	3010	4950	3810	5900
GZM-780	780	5.5	22.2	2.2	75	DN100	DN100	1985	3210	4990	4040	6200
GZM-870	870	7.5	27.8	2.2	75	DN100	DN100	1985	3210	4990	4050	6210
GZM-940	940	11	34.7	2.2	75	DN100	DN100	1985	3210	4990	4060	6220
GZM-960	960	4.0×2	18.1×2	2.2	114	DN100×2	DN100	3575	2410	4300	4920	7590
GZM-1000	1000	5.5×2	19.7×2	2.2	114	DN100×2	DN100	3575	2410	4300	4940	7610
GZM-1050	1050	7.5×2	21.9×2	2.2	114	DN100×2	DN100	3575	2410	4300	4960	7630
GZM-1165	1165	4.0×2	17.6×2	3.7	140	DN100×2	DN100	3775	2710	4950	6070	10210
GZM-1285	1285	5.5×2	21.7×2	3.7	140	DN100×2	DN100	3775	2710	4950	6090	10230
GZM-1335	1335	7.5×2	24.2×2	3.7	140	DN100×2	DN100	3775	2710	4950	6110	10250
GZM-1420	1420	5.5×2	21.7×2	3.7	140	DN100×2	DN100	3775	3010	4950	7050	11250
GZM-1490	1490	7.5×2	24.2×2	3.7	140	DN100×2	DN100	3775	3010	4950	7070	11270

### NOTE

Nominal Tons are based upon condensing temp. 37°C/ 98.6°F, WBT 26°C/ 78.8°F.

## PRODUCTS ADVANTAGES

Compatible with numerous process fluids  
(water, water/glycol, oil, other fluids)

- ◆ Capable and flexible in customized solutions
- ◆ Factory assembled for maximal installation convenience
- ◆ Modular design suits a wide range of heat rejection duties
- ◆ Compact design with minimal footprints
- ◆ Multiple corrosion resistant options
- ◆ Low sound operation options available
- ◆ More optimizing options available
- ◆ Performance and quality guaranteed
- ◆ Super long service life



## TOP DESIGN & QUALITY FEATURES

### 1 Entirely Corrosion Proof

- ◆ Enclosure made in Special Alloy Coated Steel from Nippon Steel/POSCO, or Stainless Steel;
- ◆ Heat Exchange Coils or Condenser Coils made in Stainless Steel, Red Copper, or Titanium Alloy
- ◆ Tube for Chemical Fluid Cooling;
- ◆ Structure Frame and Lifting Lug in H.D.G Steel, Fasteners in Stainless Steel, or Dacromet Treated .



### 2 Heat Exchange Performance Ensured

- ◆ Major Series Passed CTI Tests



### 3 Solid Structure

- ◆ Strong Reinforcing Bars
- ◆ Intensive Fasteners
- ◆ Low Gravity Center with Heat Exchanger in Bottom Section



### 4 Maintenance & Cleaning Convenient

- ◆ Large Entering Access
- ◆ Cooling Coils Section Visible
- ◆ Water Basin with Efficient Drain



### 5 High Unit Power Efficiency

- ◆ Advanced System Design
- ◆ Optimized Fans and Pumps



**SANJIU Standard cooling towers apply the latest type of Highly Corrosion-resistant coated steel sheet with a coating composition consisting of zinc as the main substrate, in combination with Al(11%), Mg(3%), and a trace amount of silicon. This special material is named as 'SuperDyma' by Nippon Steel.**

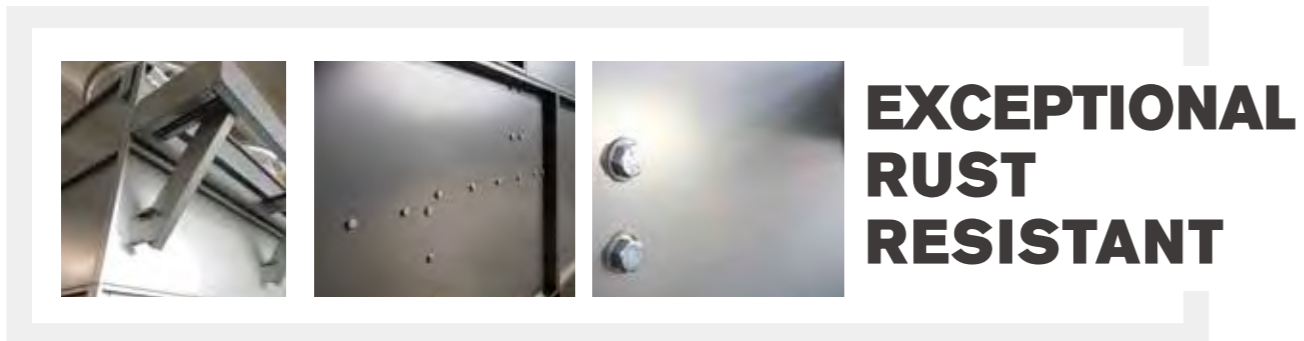

**Corrosion Resistance of Flat Surfaces**

Conventional hot-dip Zn-coated steel sheets also produce a protective film. However, this film is rough in texture, allowing the penetration of moisture and oxygen and a resultant growth of corrosion.

By contrast, the dense protective film formed on the surface of SuperDyma arrests the corrosion process and stabilizes corrosion behavior

Corrosion Resistance of Flat Surfaces (Salt Spray Tests)

Test time	Before test	500 hours	1,000 hours	2,000 hours
SuperDyma Thickness: 3.2 mm Coating mass symbol: K12 Special chromate treatment				

Corrosion Resistance of Flat Surfaces (Results of JASO)

	90 cycles	180 cycles
Hot-dip Zn-coated sheet		
SuperDyma		
Galvalume Steel Sheet		

Specime	Type of coating	Coating mass	Surface treatment	Thickness
Hot-dip Zn-coated sheet	Zn	Z27	Special chromate treatment	1.6mm
SuperDyma	-3%Mg-0.2%Si Zn-11%Al	K18		
Galvalume Steel Sheet	Zn-55%Al	AZ150		

Test conditions:  
Cyclic corrosion test (JASO M609-91 method)  
Repetition of ① to ③ as a cycle  
① Salt spray: 2 hours (5% NaCl, 35 C)  
② Drying: 4 hours (60 C)  
③ Wetting: 2 hours (50 C, humidity 95% or more)

- ◆ Not only highly rust resistant on flat surfaces;
- ◆ But also superiorly corrosion proof on cut-end surfaces, self 'recovered'.
- ◆ In addition, of extremely high alkaline resistance.

The corrosion resistance of this innovative alloy coated steel is enhanced by the composite effect of adding aluminum, magnesium and silicon to the conventional zinc coating. Silicon, among other elements, is highly effective in inhibiting corrosion when combined with Magnesium.

Corrosion Resistance at Cut-end Surfaces (Results of Salt Spray Tests)

Specimen conditions Thickness: 3.2 mm Surface treatment: No treatment	Hot-dip Zn-coated sheet Coating mass: 100 g/m <sup>2</sup> /side	SuperDyma Coating mass: 90 g/m <sup>2</sup> /side	Galvalume Steel Sheet (Laboratory trial-made sample) Coating mass: 90 g/m <sup>2</sup> /side
Salt spray test: 500 hours			

**Corrosion Resistance at Cut-end Surfaces**

**Results of Outdoor Exposure Tests**

- ◆ In the actual exposure environment outdoors, a slight degree of initial red rust occurs on cut-end surfaces, but, after a while, a stable protective film covers the cut-end surface, thus virtually arresting further progress of corrosion in the long run.
- ◆ Red rust which occurs in the initial phase is arrested in progress, with time, by the effect of the protective film and, soon entirely covered by the film, becomes quite inconspicuous.

Corrosion Resistance at Cut-end Surfaces: Middle and Latter Periods (Results of Outdoor Exposure Tests)

**Specimen conditions**  
SuperDyma  
Thickness: 3.2 mm  
Coating mass: 90g/m<sup>2</sup> /side (K18)  
Surface treatment: No treatment

Exposure site: Nippon Steel & Sumitomo Metal's weathering site at Futtsu

Set direction of cut-end surfaces

**Corrosion Resistance at Cut-end Surfaces: Initial Period**

Specimen conditions SuperDyma Thickness: 3.2mm Coating mass symbol: K27 Surface treatment: Special chromate treatment (Y treatment) Exposure site: Urayasu Plant of KANEYASU Co.	Downward
Original	
7 days	
14 days	
1 month	
2 month	
3 month	

	Upward	Sideways (The left is the underside in the photo)	Downward
8 months			
20 months			

**Superior Raw Materials, Advanced Tech Design, Precise Fabricating Equipments, All These Created Reliable Cooling Towers of SANJIU!**

# BASIC CONFIGURATIONS

## STRUCTURE & CASING



The standard enclosure is made of the latest type of Highly Corrosion-resistant coated steel sheet with a coating composition consisting of Zn+Al(11%)+Mg(3%), and a trace amount of silicon, originally imported from Nippon Steel or Posco. The panels are sheared and folded precisely in whole cold machining process, then densely bolted and sealed for water tightness, with sufficient reinforcing bars, preventing deforming during hoisting process in fields. Each tower is completed with maintenance access and doors of maximized size, for internal inspection convenience. Heat exchange section is firmly supported by frame made in stainless steel, or H.D.G steel plated entirely after welding.

## EVAPORATIVE COOLING COILS



The water cooling series adopt high efficient heat exchange coils. Optimized coils has effectively reduced air-side resistance, suitable to work with larger amount of spray water, and significantly improved heat transfer efficiency. The heat exchanger combines one or more coils supported by steel structure, firm and durable. This whole section is of patented design, easy to eliminate cooling medium fluid. Standard coils tube made in stainless steel 304/316, or red copper and titanium ally on option. Different wall thickness can be met on request. Each coil is tested under continuous nitrogen gas pressure of 30 bar for 24 hours, ensure no leaking or weak point, with guarantee provided for 18 for both raw material and design of this critical section of an evaporative cooler.

## DRY/AIR COOLING COILS



The dedicated dry cooling coils in GKM Series is used exclusively for the purpose of dry cooling, fitted with particularly shaped aluminum or steel fins around the coils tubes, to maximize heat transfer surface and efficiency. The gap between the neighbouring fins can be customized and depends on the environment and other working conditions of the project sites. Dry cooling coils with suitable fin gaps can also work with spray water in cases the temperature drop becomes a challenge in the hot season, and save operation power greatly. Rest of specifications is common to above evaporative cooling coils.



## DIRECT-DRIVE AXIAL FANS

The standard closed loop series adopt direct-drive axial fans, fitted with resin or al-alloy airfoil blades perfectly balanced and coupled to a weather proof TEFC three-phases electric motor. The fan casing is a galvanized steel cylinder to draw the air vertically and avoid the risk of recirculation. The tip speed of the impeller is limited to keep the noise level within acceptable limits.



## NON-DIRECT DRIVE AXIAL FANS

A part of open loop series adopt non-direct drive axial fans, fitted with al-alloy airfoil blades perfectly balanced and coupled with gear box or belts with speed reducer, to a weather proof TEFC three-phases electric motor. The fan casing is a galvanized steel cylinder to draw the air vertically and avoid the risk of recirculation. The tip speed of the impeller is limited to keep the noise level within acceptable limits.



## SPRAY PUMP

Standard spray pumps are of GZ horizontal centrifugal series from GSD brand, with motor of brand TECO, specially designed for evaporative cooling equipments, of generally large flow rate but low pumping head. The selected pumps are of dynamic-static balance, with shaft as an extended section from the motor, for most reliable concentricity. With first grade bearings, the pumps runat minimized vibration and low noise. Mechanicseals avoids abrasion to shaft, no leakage in long term service life. Overload protected on any point of the performance curve, not exceeding the rated power during the whole working period. Enclosure materials and installation arrangement can be optional and modified to suit different projects requirements.

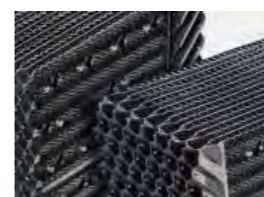

## WET DECK FILL

The fills are formed in flame-retardant PVC sheets with a special shape design of herringbone surface, to distribute water evenly over the entire fill area for maximal thermal performance, can be integrated with air inlet louvers and drift eliminators. For medium fouled water, fill types with enlarged grids are available to reduce the chances of blocks. All the raw materials are of virgin grade from approved suppliers, with long service life in tough environment.



## DRIFT ELIMINATOR

Cellular Drift Eliminators are specifically designed to achieve maximum drift removal, with significantly lower pressure drop. The modules are constructed of a series of sinusoidal-shaped, corrugated PVC sheets that are mechanically assembled to mating sinusoidal structural waves, forming closed cells. These cells force the drift droplets being carried in the leaving airstream to make three distinct changes in direction. When the air is forced to change direction, the inertia of the water droplets keeps them moving in a straight line, causing them to impact the wall of the drift eliminator and drain back into the wet section of the tower.

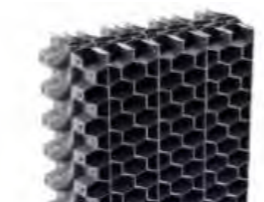

## AIR INLET LOUVERS

Cellular air Inlet louvers with advaned design improve air flow into the cooling tower, keep out debris, eliminate water splash-out, which otherwise can cause icing, near-site water damage, and unnecessary water loss. The deign restrict the amount of sunlight into the cooling tower to impede algae growth, reduce noise from the tower, and improve the tower's appearance.

## BASIC CONFIGURATIONS



### SPRAY NOZZLES FOR OPEN TOWERS

The Spiral Target Nozzles used for GOM Series open towers, injection molded in polypropylene unit consisting of two parts, main body with integral target diffuser and a snap-on insert or orifice cap. The nozzles installed in bottom of the hot water distribution basins, to eliminate water diffusion decks below the hot water basins, provide full water coverage of the fills by gravity flow, removable and replaceable but of long service life. Sizes and variety depends on the tower size, water flow rate and water quality.



### SPRAY PIPE

Spray Pipes made in U-PVC from FPC, of high mechanical strength and long service life, holding pressure 1.0 Mpa, accessible to inspect and maintain from outside of the tower, convenient to check with when running fully, completed with buttonholes for quick and tight installations of spray nozzles.



### FLOAT VALVE

Heavy duty floating valve, made in stainless steel, floating ball in engineering plastic or stainless steel, with long service life. Water level adjustable.



### ANTI-EDDY FILTER

Effectively filtering the sundries, with anti-eddy arrangement, preventing air bubbles sucked into the pumps, punched in the same material as the enclosure, highly corrosion resistant.



### FASTNERS

Fastners of leading brands, standard materials in steel dacromet treated, stainless steel on options. Intensity of fastners is higher than average.

## OPTIONAL CONFIGURATIONS



### CONTROL PANEL

The control panel is optional for each cooling tower, or a group of towers can share a central control station. The enclosure can be made in powder coated carbon steel, or stainless steel on options, with or without weather proof arrangement.



### PLC DIGITAL CONTROL

In cases digital or remote control function required, the PLC can be applied and programmed according to the project demands, with or without PC connection terminal, usually of brand Simens or AB.



### CIRCULATION AUXILIARY SECTION

Circulation Pumps with Transfer Water Tank, as an integrated solution of circulating system, with PID design on request.



### FREQUENCY CONTROL

An optional part to adjust the frequency of power supply.



### PROTECTIVE GUARDS AND MAINTENANCE LADDER

For maintenance convenience and safety, made in HDG steel or stainless steel.



### LOW NOISE FANS

Fans with low noise design, suitable for installation locations with strict noise limit, 6 to 12 db(a) lower than standard fan system.



### VIBRATION REDUCER

An optional part applied to reduce running vibration when necessary, of nature frequency 2.16Hz ~ 4.79Hz



### VIBRATION LIMIT SWITCH

Used to switch off the tower automatically when the vibration is out of limit when the tower is working abnormally.



### ELETRICAL HEATER

Applied to heat the freezing water when restarting the tower during winter season in some area



### AUTO MAKE UP UNIT

An optional part to make up the liquid automatically, to be working together with liquid level controller.

# CUSTOMIZED SOLUTIONS

Casing in Stainless Steel



Surface Finish with Paint



Integrated Solution with Frame and Circulation System



Explosion Proof Treatment



Heat Exchange Section in Titanium for Superior Corrosion Resistant



Water/ Air Cooling Hybrid



Auto Anti- Freeze Structure



Fog Dissipation Treatment



Fabricating at Project Site

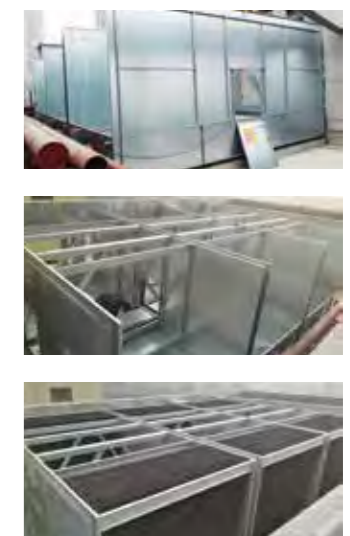

# TYPICAL PROJECTS

## Air Compressor Cooling First Auto Works



◆ Stage IV



◆ Stage I



◆ Stage II



◆ Stage III

## HVAC Cooling Changzhou Pharmaceutical Factory, Johnson Controls Plant



◆ For YORK A/C



◆ For Trane A/C

# TYPICAL PROJECTS

## Vacuum Furnace Cooling



◆ For Jinfei Holding Group



◆ For IHI Feng Dong

## Melting Furnace Cooling



◆ For SiDa MF. Induction Furnace



# TYPICAL PROJECTS

## Oil and Other Process Fluid Cooling



◆ DONGFENG-NISSAN /Massive Quenching Oil



◆ Hangzhou Sannai Enviroment/ Transformer Oil



◆ Pusheng Chemical/ Formaldehyde

## Groud Source Heat Pump System Cooling



◆ Xuyi Hospital



◆ Tsinghua Tonfang

# TYPICAL PROJECTS

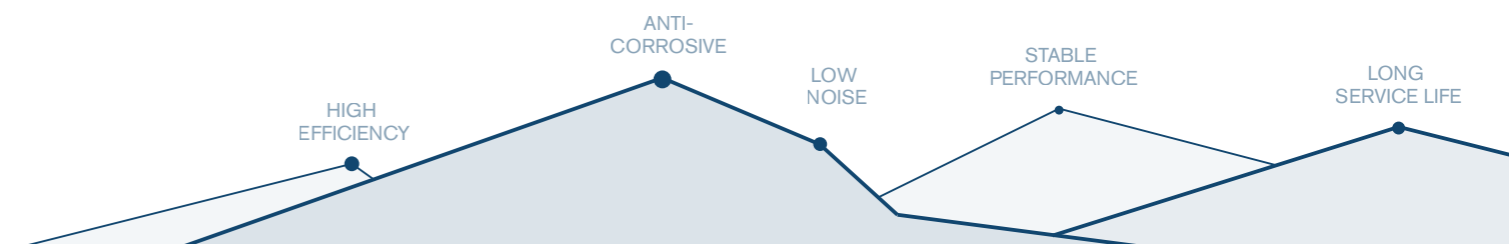

◆ For Tsingtao Brewaery

## OTHER UTILITIES COOLING

Data Centers,  
 Frequency Converters,  
 Injection Machines, Printing Lines,  
 Drawbenches, Polycrystalline Furnaces, etc.



◆ For Tsingtao Brewaery



◆ For Xinjiang Baomo Petrochemical



◆ For Zhiguang Electric

# TYPICAL PROJECTS



◆ For Xinjiang Baomo Petrochemical



◆ For New United Group

# TRANSPORTATION CONVENIENCE



The products are of considerate modular design and tailor-made to suit containers loading, or flat racks for extremely large models, firmly fixed for transportation safety.



# TECH SUPPORT & INSTALLATION GUIDES

## RECOMMENDED SPRAY WATER CONDITION

Items	Standard Value	
	When the temp. of circulating water < 20°C	When the temp. of circulating water if between 20°C~60°C
Ph value	6.8~8.0	7.8~8.0
Conductivity (ms/cm)	< 40	< 30
Chloride rate (mg C1 <sup>-</sup> /L)	< 50	< 50
Sulphate rate (mg S04 <sup>2-</sup> /L)	< 50	< 50
Acid consumption rate(Ph4.8)(mg CaCO3/L)	< 50	< 50
Total hardness(mg CaCO3/L)	< 70	< 70
Calcium hardness(mg CaCO3/L)	< 50	< 50
CO2 ionized rate (mg Sio2/L)	< 30	< 30
Iron ion rate (mg Fe/L)	< 1.0	< 1.0
Copper ion rate ( mg Cu/L)	< 1.0	< 1.0
Residual Chloride rate(mg C1/L)	< 0.3	< 0.3
Ammonium ion rate (mg NH4 <sup>+</sup> /L)	< 1.0	< 1.0
Residual Carbonic acid rate(mg CO2/L)	< 4.0	< 0.4

## SPECIAL NOTES FOR WINTERTIME OR COLD ENVIRONMENT OPERATION

To prevent the cracking of condenser coils and the reticulation system in general, please take the precautions below when operating in cold environments.

When the ambient temperature is lower than -10°C, it is necessary to add an antifreeze agent to prevent the recirculating water from freezing. Typical dosing rates for glycol based antifreeze please refer to below chart, or please consult us for further advice.

Glycol (%)	0	10	20	30	40	50	58
Freezing point (°C)	-0.0	-3.5	-8	-15	-24	-36	-48

### NOTE

If the tower is idle when the ambient temperature is below 0°C, it will be essential to completely drain all water from the tower and associated piping.

## 1.LOCATION

The cooling tower should be installed on a solid floor, to avoid resonance, vibration and noise. The tower should be located in an open area, with sufficient space - about 2 meters away from any wall to allow for effective air flow. The location should be free of airborne pollutants – and away from acidic and explosive environments in particular.

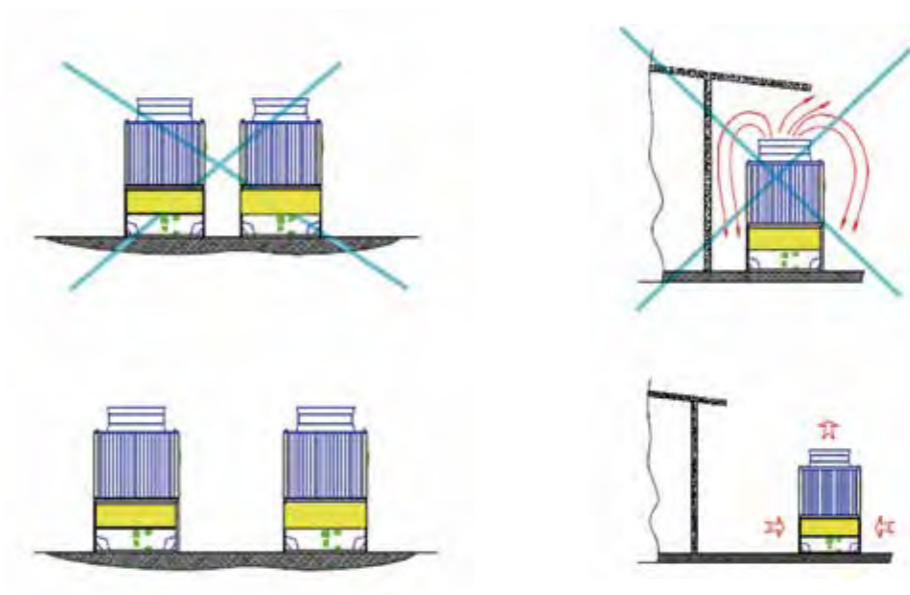

## 2.PRECAUTIONS

- Check the nameplate and confirm the power supply is suitable for the tower
- Prevent backflow of water vapor or hot wet air
- Provide drainage around the tower (fall > 0.8%) around the base of the tower to remove any condensate water or minor overspray
- Comply with all local Electrical and Building Regulations during the installation

## 3.PLUMBING

- Select a suitable type and size of water pipe to connect the water inlet and outlet
- Fix the external water pipes properly. Pipes must not be supported by the tower

## 4.ELECTRICAL CONNECTION

- Standard power supply is 380V±10%, 3-Phase, 50 Hz. If this has been customized to your requirements, the details will be indicated on the tower nameplate as well as at the front of the instruction manual.
- For further details, please refer to the Electrical Diagram Drawings provided along with the tower.

### NOTE

Foundation design is provided for each project. Commissioning & Operation guides please refer to the service manual of each product. For further technical support, please contact us.