



xLED

xLED-SAM-8050 Pin Fin LED Heat Sink Φ 80mm for Samsung

Features VS Benefits

- * The xLED-SAM-8050 Samsung Pin Fin LED Heat Sinks are specifically designed for luminaires using the Samsung LED engines.
- * Mechanical compatibility with direct mounting of the LED engines to the LED cooler and thermal performance matching the lumen packages.
- * For spotlight and downlight designs from 1,100 to 3,400 lumen.
- * Thermal resistance range R_{th} 2.38°C/W.
- * Modular design with mounting holes foreseen for direct mounting of Samsung LED engines.
- * Diameter 80.0mm - standard height 50.0mm, Other heights on request.
- * Forged from highly conductive aluminum.



Zhaga LED engine and radiator assembly is a unified future international standardization

- * Below you find an overview of Samsung COB's and LED modules which standard fit on the Pin Fin LED Heat Sinks.
- * In this way mechanical after work and related costs can be avoided, and lighting designers can standardize their designs on a limited number of LED Pin Fin LED Heat Sink.

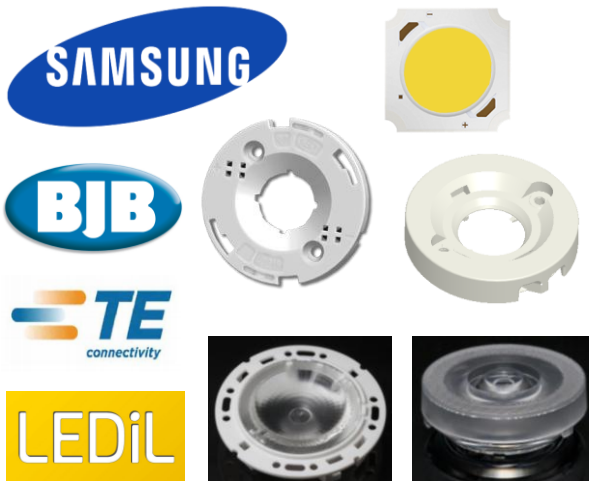

Samsung LED Modules directly Mounting Options

Samsung B Series LED modules name:

L026B;
L033B;
L040B;

With the Zhaga Book 3 holders for the green indicator marks.
BJB Holder: 47.319.2254.50;
TE LED Holder: 2213258-1;
Without the holders for the red indicator marks.
Direct mounting with machine screws M3x6.5mm.

Samsung D Series LED modules name:

LC016D;
LC019D;
LC026D;

With the Zhaga Book 3 holders for the green indicator marks.
BJB Holder: 47.319.2021.50;
TE LED Holder: 2213254-1;
Direct mounting with machine screws M3x6.5mm.

With the LEDiL products:

Ronda series: FN15xxx;
Olivia series: FN14828-M; FN14637-S;

Samsung C Series LED modules name:

LC040C;

With the Zhaga Book 3 holders for the green indicator marks.
TE LED Holder: 2213382-1;
Direct mounting with machine screws M3x6.5mm.

With the LEDiL products:

Ronda series: FN15xxx;

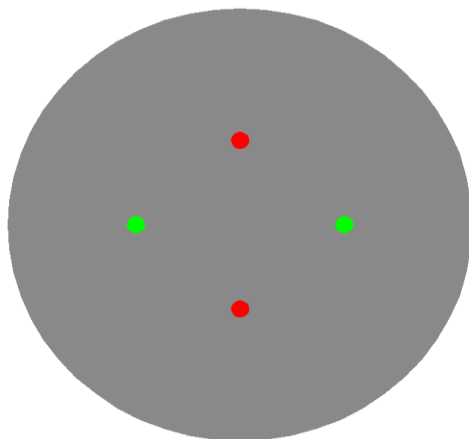

xLED

xLED-SAM-8050 Pin Fin LED Heat Sink Φ 80mm for Samsung

Mounting Options and Drawings & Dimensions

Example:xLED-SAM-8050-B-1,2

Example:xLED-SAM-80 **1** - **2** - **3**

- 1** Height (mm)
- 2** Anodising Color
B-Black
C-Clear
Z-Custom
- 3** Mounting Options - see graphics for details Combinations available
Ex.order code - 12
means option 1 and 2 combined

Notes:

- Mentioned models are an extraction of full product range.
- For specific mechanical adaptations please contact MingfaTech.
- MingfaTech reserves the right to change products or specifications without prior notice.

MOUNTING OPTION	Module type	Holder NO.	LEDiL products		THREAD	THREAD DEPTH	THREAD HOLE DISTANCE
			Olivia series	Ronda series			
N	/	None	None	None	None	None	None
1		/			M3	6.5mm	30.4mm/ 2-@180°
2	L026B; L033B; L040B;	BJB Holder 47.319.2254.50 TE Holder 2213258-1	/	/	M3	6.5mm	35.0mm/ 2-@180° (Zhaga book 3)
	L016D; L018D; L026D;	BJB Holder 47.319.2021.50 TE Holder 2213254-1	FN14828-M; FN14637-S;				
	L040C;	TE Holder 2213382-1	/	FN15xxx;			

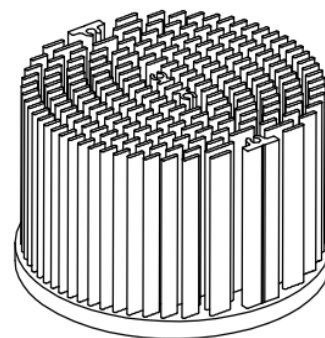
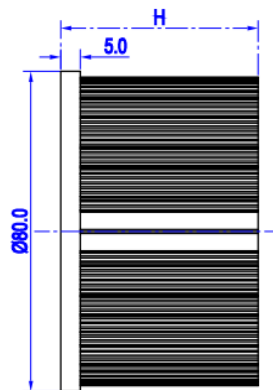
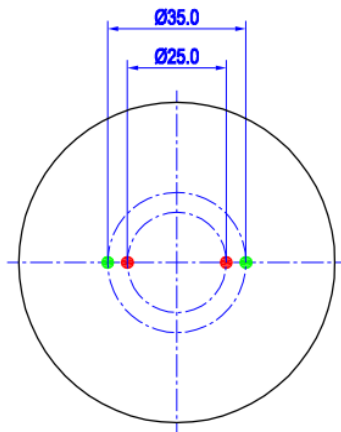

xLED

xLED-SAM-8050 Pin Fin LED Heat Sink Φ 80mm for Samsung

The product data table

	Model No.	xLED-SAM-8050
	Heatsink Size	Φ 80xH50mm
	Heatsink Material	AL1070
	Finish	Black Anodized
	Weight (g)	197.0
	Dissipated power (T_{hs-amb},50°C)	21.0 (W)
	Cooling surface area (mm²)	120774
	Thermal Resistance (R_{hs-amb})	2.38 (°C/W)

The thermal data table

* Please be aware the dissipated power Pd is not the same as the electrical power Pe of a LED module.

*To calculate the dissipated power please use the following formula: Pd = Pe x (1-ηL).

Pd - Dissipated power ; Pe - Electrical power ; ηL = Light efficiency of the LED module;

Dissipated Power Pd(W)	Pd = Pe x (1-ηL)	Heat sink to ambient thermal resistance R _{hs-amb} (°C/W)	Heat sink to ambient temperature rise T _{hs-amb} (°C)
		xLED-SAM-8050	
6.0		3.50	21.0
12.0		2.92	35.0
18.0		2.56	46.0
24.0		2.29	55.0
32.0		2.00	64.0

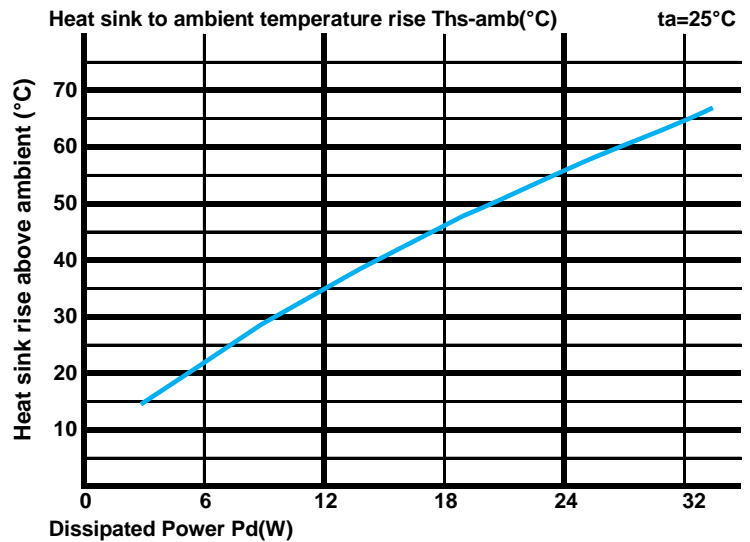

*The aluminum substrate side of the package outer shell is thermally connected to the heat sink via TIM (Thermal interface material).

MingFa recommends the use of a high thermal conductive interface between the LED module and the LED cooler.

Either thermal grease, A thermal pad or a phase change thermal pad thickness 0.1-0.15mm is recommended.



*Thermal resistance is a heat property and a measurement of a temperature difference by which an object or material resists a heat flow.

Geometric shapes are different, the thermal resistance is different. Formula: $\theta = (T_{hs} - T_a) / P_d$

θ - Thermal Resistance [°C/W]; T_{hs} - Heatsink temperature; T_a - Ambient temperature;

*The thermal resistance between the junction section of the light-emitting diode and the aluminum substrate side of the package outer shell is R_{junction-case}, the thermal resistance of the TIM outside the package is R_{interface (TIM)} [°C/W], the thermal resistance with the heat sink is R_{heatsink-ambient} [°C/W], and the ambient temperature is T_{ambient} [°C].

*Thermal resistances outside the package R_{interface (TIM)} and R_{heatsink-ambient} can be integrated into the thermal resistance R_{case-ambient} at this point. Thus, the following formula is also used:

$$T_{\text{junction}} = (R_{\text{junction-case}} + R_{\text{case-ambient}}) \cdot P_d + T_{\text{ambient}}$$