



LED

xLED

xLED-LG-4530 Pin Fin Heat Sink Φ 45mm for LG Innotek

Features VS Benefits

- * The xLED-LG-4530 LG Innotek Pin Fin LED Heat Sinks are specifically designed for luminaires using the LG Innotek LED engines.
- * Mechanical compatibility with direct mounting of the LED engines to the LED cooler and thermal performance matching the lumen packages.
- * For spotlight and downlight designs from 300 to 1,200 lumen.
- * Thermal resistance range R_{th} 7.14°C/W.
- * Modular design with mounting holes foreseen for direct mounting of LG Innotek COB series.
- * Diameter 45.0mm - standard height 30.0mm Other heights on request.
- * Forged from highly conductive aluminum.



Zhaga LED engine and radiator assembly is a unified future international standardization

- * Below you find an overview of LG Innotek COB's and LED modules which standard fit on the Pin Fin LED Heat Sinks.
- * In this way mechanical after work and related costs can be avoided, and lighting designers can standardize their designs on a limited number of LED Pin Fin LED Heat Sink.



LG Innotek LED Modules directly Mounting Options

LG Innotek 7W&10W COB series.

- LEMWM19480xxxxxx;
- LEMWM19490xxxxxx;
- LEMWM19680xxxxxx;
- LEMWM19690xxxxxx;

With the Zhaga Book 3 holders for the green indicator marks.
TE Connectivity Holder: 2213382-1;
Without the holders for the blue indicator marks.
Direct mounting with machine screws M3x6.5mm.

LG Innotek 16W&21W COB series.

- LEMWM24780xxxxxx;
- LEMWM24790xxxxxx;
- LEMWM24980xxxxxx;
- LEMWM24990xxxxxx;

With the Zhaga Book 3 holders for the green indicator marks.
TE Connectivity Holder: 2213130-1;
BJB Holder: 47.319.2011.50;
Without the holders for the red indicator marks.
Direct mounting with machine screws M3x6.5mm.

With the LEDiL products:
Olivia series: FN14637-S; FN14828-M;

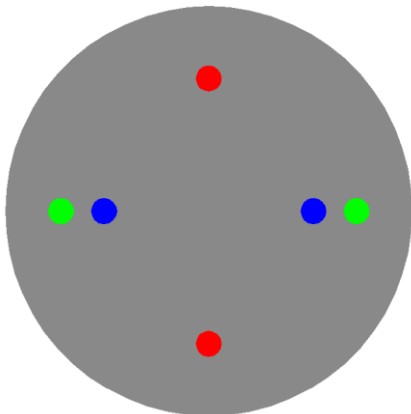



LED

xLED

xLED-LG-4530 Pin Fin Heat Sink Φ 45mm for LG Innotek

Mounting Options and Drawings & Dimensions

Example: xLED-LG-4530-B-1,2

Example: xLED-LG-45 **1** - **2** - **3**

- 1** Height (mm)
- 2** Anodising Color
 - B-Black
 - C-Clear
 - Z-Custom
- 3** Mounting Options - see graphics for details Combinations available
Ex.order code - 12
means option 1 and 2 combined

Notes:

- Mentioned models are an extraction of full product range.
- For specific mechanical adaptations please contact MingfaTech.
- MingfaTech reserves the right to change products or specifications without prior notice.

MOUNTING OPTION	Module type	Holder NO.	LEDIL products		THREAD	THREAD DEPTH	THREAD HOLE DISTANCE
			Stella Series	Olivia series			
1	7W&10W COB	/	/	FN14637-S; FN14828-M;	M3	6.5mm	24.8mm/ 2-@180°
2		/			M3	6.5mm	31.2mm/ 2-@180°
3	16W&21W COB	BJB Holder 47.319.2011.50			M3	6.5mm	35.0mm/ 2-@180° (Zhaga Book 3)
	7W&10W COB	TE Holder 2213130-1					
		TE Holder 2213382-1					

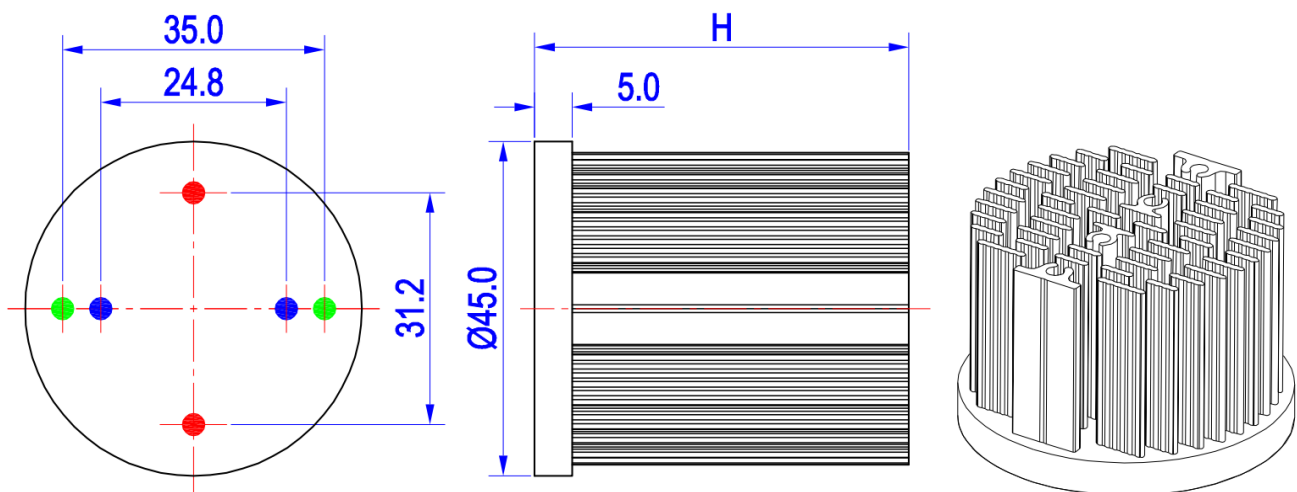

xLED

xLED-LG-4530 Pin Fin Heat Sink $\Phi 45\text{mm}$ for LG Innotek

The product data table

	Model No.	xLED-LG-4530
	Heatsink Size	$\Phi 45 \times H 30\text{mm}$
	Heatsink Material	AL1070
	Finish	Black Anodized
	Weight (g)	45.0
	Dissipated power ($T_{hs-amb}, 50^\circ\text{C}$)	7.0 (W)
	Cooling surface area (mm^2)	22830
	Thermal Resistance (R_{hs-amb})	7.14 ($^\circ\text{C}/\text{W}$)

The thermal data table

* Please be aware the dissipated power P_d is not the same as the electrical power P_e of a LED module.

* To calculate the dissipated power please use the following formula: $P_d = P_e \times (1 - \eta_L)$.

P_d - Dissipated power ; P_e - Electrical power ; η_L = Light efficiency of the LED module;

Dissipated Power P_d (W)	Heat sink to ambient thermal resistance R_{hs-amb} ($^\circ\text{C}/\text{W}$)		Heat sink to ambient temperature rise T_{hs-amb} ($^\circ\text{C}$)	
	xLED-LG-4530			
2.0	10.50	21.0		
4.0	8.50	34.0		
6.0	7.50	45.0		
8.0	7.00	56.0		
10.0	6.70	67.0		

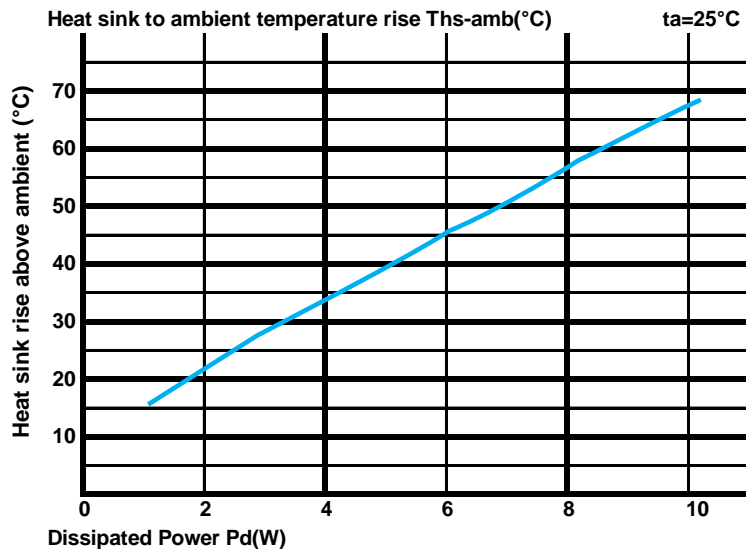

*The aluminum substrate side of the package outer shell is thermally connected to the heat sink via TIM (Thermal interface material).

MingFa recommends the use of a high thermal conductive interface between the LED module and the LED cooler.

Either thermal grease, A thermal pad or a phase change thermal pad thickness 0.1-0.15mm is recommended.

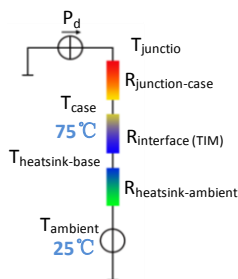

*Thermal resistance is a heat property and a measurement of a temperature difference by which an object or material resists a heat flow.

Geometric shapes are different, the thermal resistance is different. Formula: $\theta = (T_{hs} - T_a) / P_d$

θ - Thermal Resistance [$^\circ\text{C}/\text{W}$]; T_{hs} - Heatsink temperature; T_a - Ambient temperature;

*The thermal resistance between the junction section of the light-emitting diode and the aluminum substrate side of the package outer shell is $R_{\text{junction-case}}$, the thermal resistance of the TIM outside the package is $R_{\text{interface (TIM)}}$ [$^\circ\text{C}/\text{W}$], the thermal resistance with the heat sink is $R_{\text{thsink-ambient}}$ [$^\circ\text{C}/\text{W}$], and the ambient temperature is T_{ambient} [$^\circ\text{C}$].

*Thermal resistances outside the package $R_{\text{interface (TIM)}}$ and $R_{\text{thsink-ambient}}$ can be integrated into the thermal resistance $R_{\text{case-ambient}}$ at this point. Thus, the following formula is also used:

$$T_{\text{junction}} = (R_{\text{junction-case}} + R_{\text{case-ambient}}) \cdot P_d + T_{\text{ambient}}$$