

EtraLED

EtraLED-TRI-8580 Tridonic Modular Passive Star LED Heat Sink ϕ

Features VS Benefits

- * The EtraLED-TRI-8580 Tridonic Pin Fin LED Heat Sinks are specifically designed for luminaires using the Tridonic LED engines.
- * Mechanical compatibility with direct mounting of the LED engines to the LED cooler and thermal performance matching the lumen packages.
- * For spotlight and downlight designs from 2000 to 5,100 lumen.
- * Thermal resistance range R_{th} 34°C/W.
- * Modular design with mounting holes foreseen for direct mounting of Tridonic SLE series modules.
- * Diameter 85.0mm - standard height 80.0mm, Other heights on request.
- * Forged from highly conductive aluminum.



Zhaga LED engine and radiator assembly is a unified future international standardization

- * Below you find an overview of Tridonic COB's and LED modules which standard fit on the srar LED heat sinks.
- * In this way mechanical after work and related costs can be avoided, and lighting designers can standardize their designs on a limited number of srar LED heat sinks.

TRIDONIC

enlightening your ideas



STUCCHI
ideas are made of light



Tridonic LED Modules directly Mounting Options.

Modules SLE EXCITE, FOOD, ART, FASHION Series.

Modules SLE ADVANCED, G6 ADV Series.

SLE G6 19mm 5000lm-xxx;

SLE G6 23mm 6000lm-xxx;

With the Zhaga Book 3 holders for the blue indicator marks.

Direct mounting with machine screws M3x6.5mm.

Modules SLE EXCITE, FASHION, TINGE series.

Modules SLE ADVANCED, G5 XD ADV and G6 ADV Series.

Modules SLE ESSENCE, G6 SNC Series.

SLE G6 15mm 3000lm-xxx;

SLE G6 17mm 4000lm-xxx;

With the Zhaga Book 3 holders for the blue indicator marks.

BJB holder: 47.319.2021.50; AAG.STUCCHI: 8101-G2

Without the holders for the red indicator marks.

Direct mounting with machine screws M3x6.5mm.

With the LEDiL products:

Olivia series: FN14637-S; FN14828-M;

Ronda series: FN15xxx-xx;

Modules SLE EXCITE, FASHION, TINGE series.

Modules SLE ADVANCED, G6 ADV Series.

SLE G6 10mm 1200lm-xxx;

With the Zhaga Book 11 holders for the green indicator marks.

BJB Holder:47.319.6020.50;

Without the holders for the pink indicator marks.

Direct mounting with machine screws M3x6.5mm.

With the LEDiL products:

Ronda series: FN15xxx-xx;

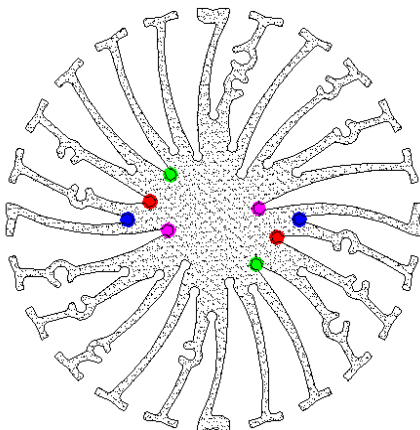

EtraLED

EtraLED-TRI-8580 Tridonic Modular Passive Star LED Heat Sink Φ

Mounting Options and Drawings & Dimensions

Example: EtraLED-TRI-8580-B-1,2

Example: EtraLED-TRI-85 **1** - **2** - **3**

1 Height (mm)

2 Anodising Color

B-Black

C-Clear

Z-Custom

3 Mounting Options - see graphics for details Combinations available

Ex.order code - 12

means option 1 and 2 combined

Notes:

- Mentioned models are an extraction of full product range.
- For specific mechanical adaptations please contact MingfaTech.
- MingfaTech reserves the right to change products or specifications without prior notice.

MOUNTING OPTION	Module type	Holder NO.	LEDiL products		THREAD	THREAD DEPTH	THREAD HOLE DISTANCE
			Olivia Series	Ronda series			
1	SLE G6 10mm;	/	/		M3	6.5mm	19.0mm/ 2-@180°
2		BJB Holder 47.319.6020.50			M3	6.5mm	25.0mm/ 2-@180° (Zhaga book 11)
3	SLE G6 15mm; SLE G6 17mm;	/	FN14637-S; FN14828-M;	FN15xxx-xx;	M3	6.5mm	26.8mm/ 2-@180°
4		BJB Holder 47.319.2021.50 AAG.STUCCHI 8101-G2			M3	6.5mm	35.0mm/ 2-@180° (Zhaga book 3)

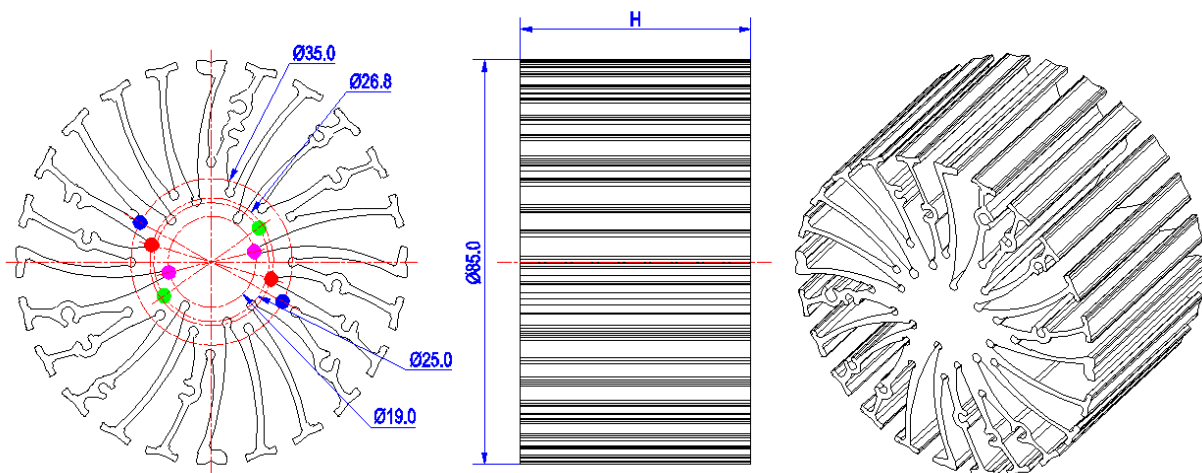

EtraLED

EtraLED-TRI-8580 Tridonic Modular Passive Star LED Heat Sink Φ

The product data table

	Model No.	EtraLED-TRI-8580
	Heatsink Size	$\Phi 85 \times H 80 \text{mm}$
	Heatsink Material	AL6063-T5
	Finish	Black Anodized
	Weight (g)	458.0
	Dissipated power (T_{hs-amb}, 50°C)	34.0 (W)
	Cooling surface area (mm²)	148458
	Thermal Resistance (R_{hs-amb})	1.47 (°C/W)

The thermal data table

* Please be aware the dissipated power Pd is not the same as the electrical power Pe of a LED module.

*To calculate the dissipated power please use the following formula: $P_d = P_e \times (1 - \eta_L)$.

Pd - Dissipated power ; Pe - Electrical power ; η_L = Light efficiency of the LED module;

Dissipated Power Pd(W)	Pd = Pe x (1- η_L)	Heat sink to ambient thermal resistance R _{hs-amb} (°C/W)	Heat sink to ambient temperature rise Ths-amb (°C)
		EtraLED-TRI-8580	
8.0		2.25	18.0
16.0		1.88	30.0
24.0		1.67	40.0
32.0		1.50	48.0
40.0		1.40	56.0

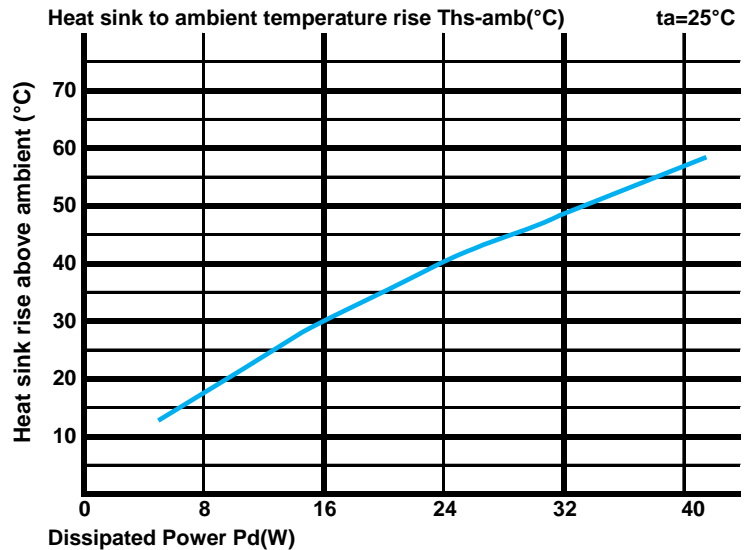

*The aluminum substrate side of the package outer shell is thermally connected to the heat sink via TIM (Thermal interface material).

MingFa recommends the use of a high thermal conductive interface between the LED module and the LED cooler.

Either thermal grease, A thermal pad or a phase change thermal pad thickness 0.1-0.15mm is recommended.

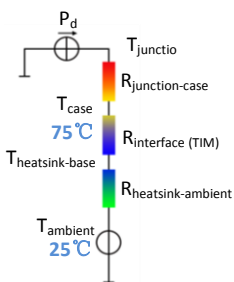

*Thermal resistance is a heat property and a measurement of a temperature difference by which an object or material resists a heat flow.

Geometric shapes are different, the thermal resistance is different. Formula: $\theta = (T_{hs} - T_a) / P_d$

θ - Thermal Resistance [°C/W]; T_{hs} - Heatsink temperature ; T_a - Ambient temperature ;

*The thermal resistance between the junction section of the light-emitting diode and the aluminum substrate side of the package outer shell is R_{junction-case}, the thermal resistance of the TIM outside the package is R_{interface (TIM)} [°C/W], the thermal resistance with the heat sink is R_{heatsink-ambient} [°C/W], and the ambient temperature is T_{ambient} [°C].

*Thermal resistances outside the package R_{interface (TIM)} and R_{heatsink-ambient} can be integrated into the thermal resistance R_{case-ambient} at this point. Thus, the following formula is also used:

$$T_{\text{junction}} = (R_{\text{junction-case}} + R_{\text{case-ambient}}) \cdot P_d + T_{\text{ambient}}$$