

Application

Mainly used in printer, scanner, stage light etc.

Picture

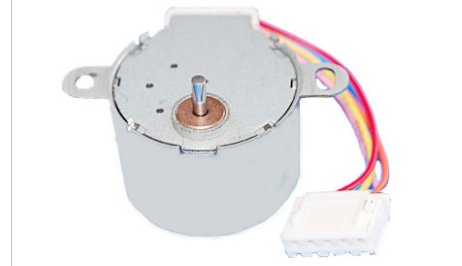

Complementary Products:

- Output Shaft
- Assembling Size
- Lead Wire or Terminal

Specification

MODEL	No. of phase	Step Angle °	Voltage V	Speed Ratio	Resistance Ω	Starting Frequency P.P.S	Pulling Torque (100P.P.S) g.cm	Detent Torque g.cm	Wiring	Figure
P284-0305	4	5.625	12	1:64	300	≥550	≥300	≥300	Alternative	

Mechanical Dimensions

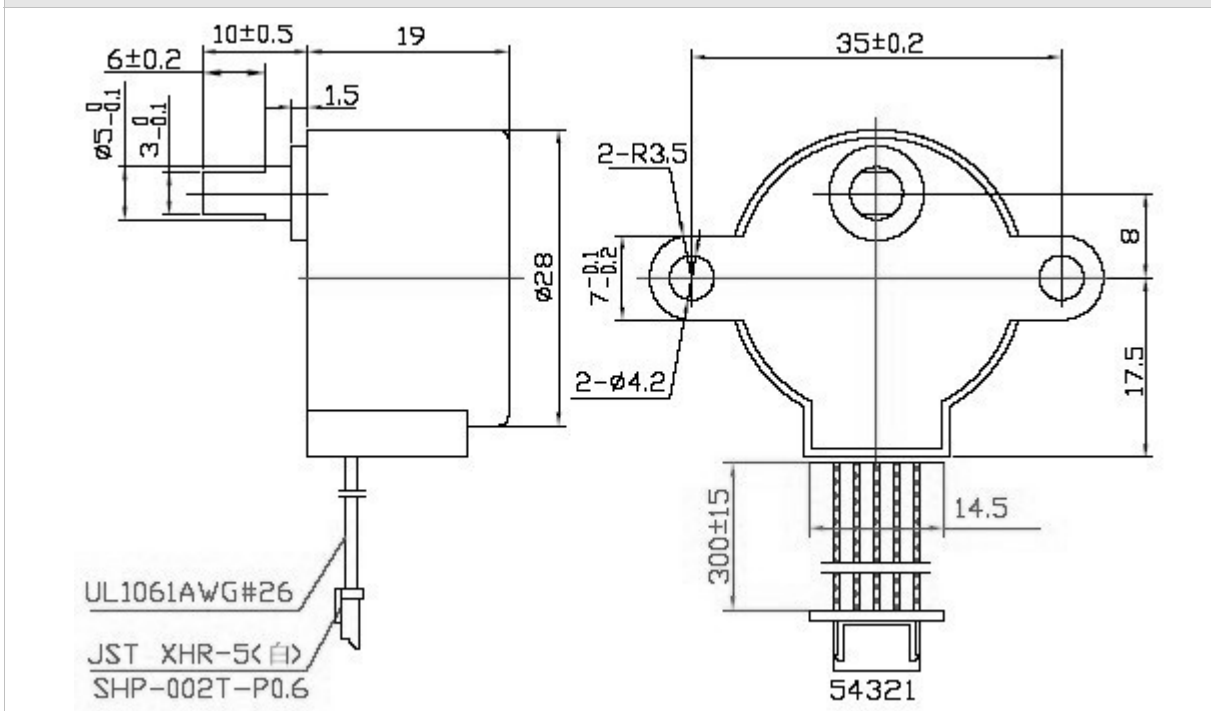

Standard Leadwire Configuration

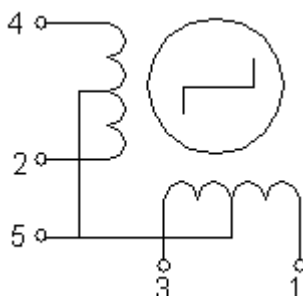

4-1-2 excitation

Pin No.	Wire Color	Step							
		1	2	3	4	5	6	7	8
5	RED	+	+	+	+	+	+	+	+
4	OR	-	-						
3	YEL		-	-					
2	PIN				-	-	-		
1	BLU						-	-	-

→ CCW direction (from shaft end)